

	SANDERO II	
	SANDERO STEPWAY	
	LOGAN II	
	SYMBOL	
	LOGAN II MVC	

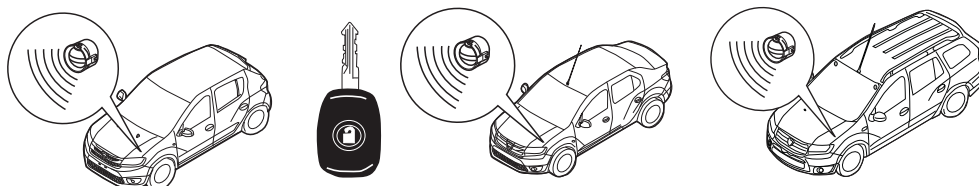

82 01 302 697

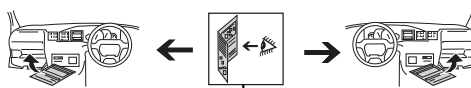

[Http:// tech-accessoires.renault.com](http://tech-accessoires.renault.com)

(FRA) Instructions de montage	(CRO) Návod k montáži	(PLK) Instrukcje wbudowania
(CZA) Pokyny pro montáž	(HUN) Beépítési utasítások	(PTG) Instruções de montagem
(DAN) Monteringsveiledning	(ITA) Istruzioni per il montaggio	(ROM) Instrucțiuni de montaj
(DEU) Einbauanleitung	(JPN) 取付説明書	(RUS) Инструкция по монтажу
(ENG) Installation instructions	(KOR) 조립설명서	(SLK) Návod na zabudovanie
(ESP) Instrucciones de montaje	(LTH) Montavimo instrukcija	(SLV) Navodila za inštalacijo
(EST) Paigaldusjuhised	(LET) Montāžas instrukcijas	(SWE) Montageanvisning
(FIN) Asennusohje	(NLD) Inbouwhandleiding	(TRK) Montaj talimatları
(GRK) Οδηγίες συναρμολόγησης	(NOR) Monteringsveiledning	

82 01 302 697 - - E

18/11/2013

1/40

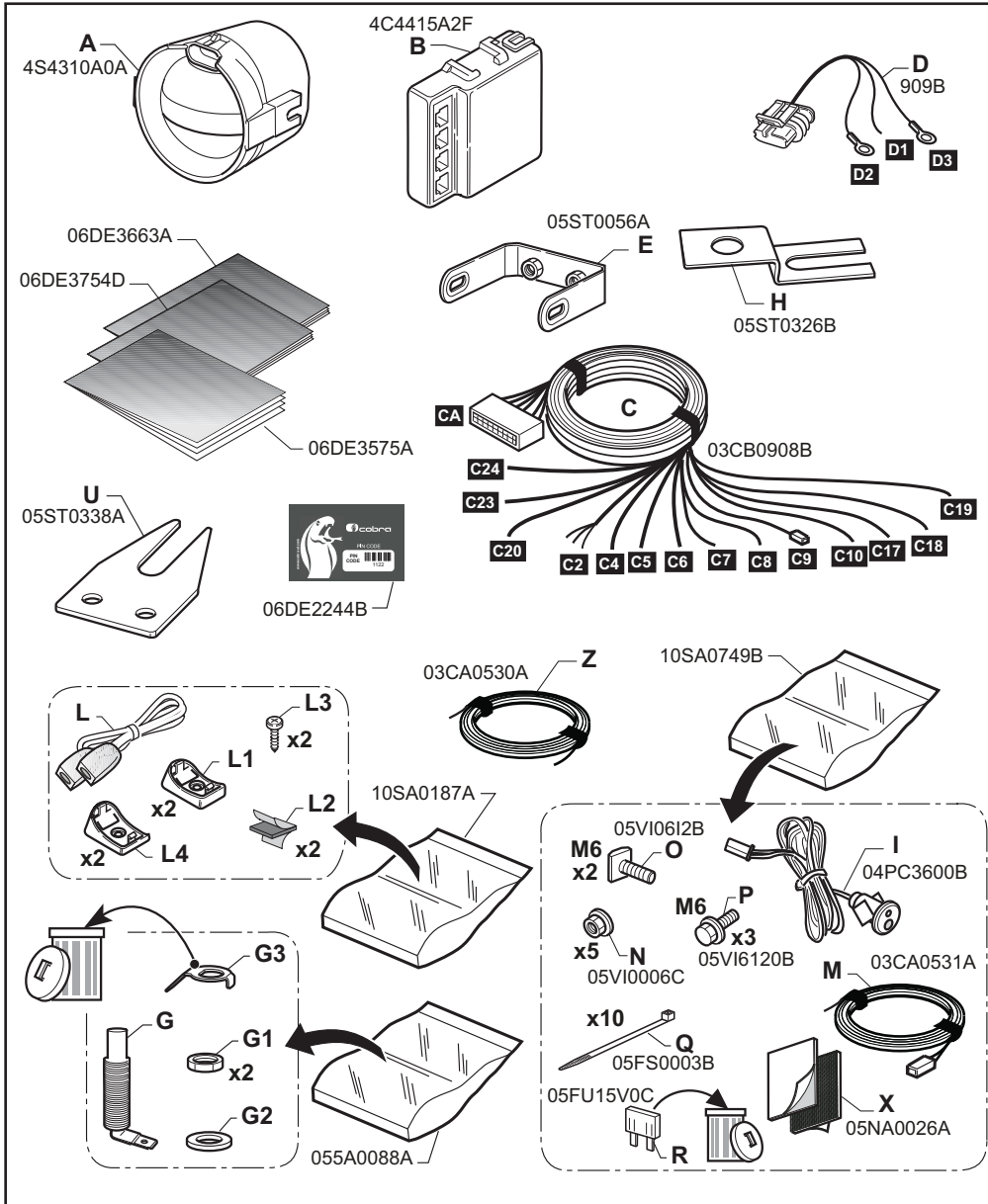

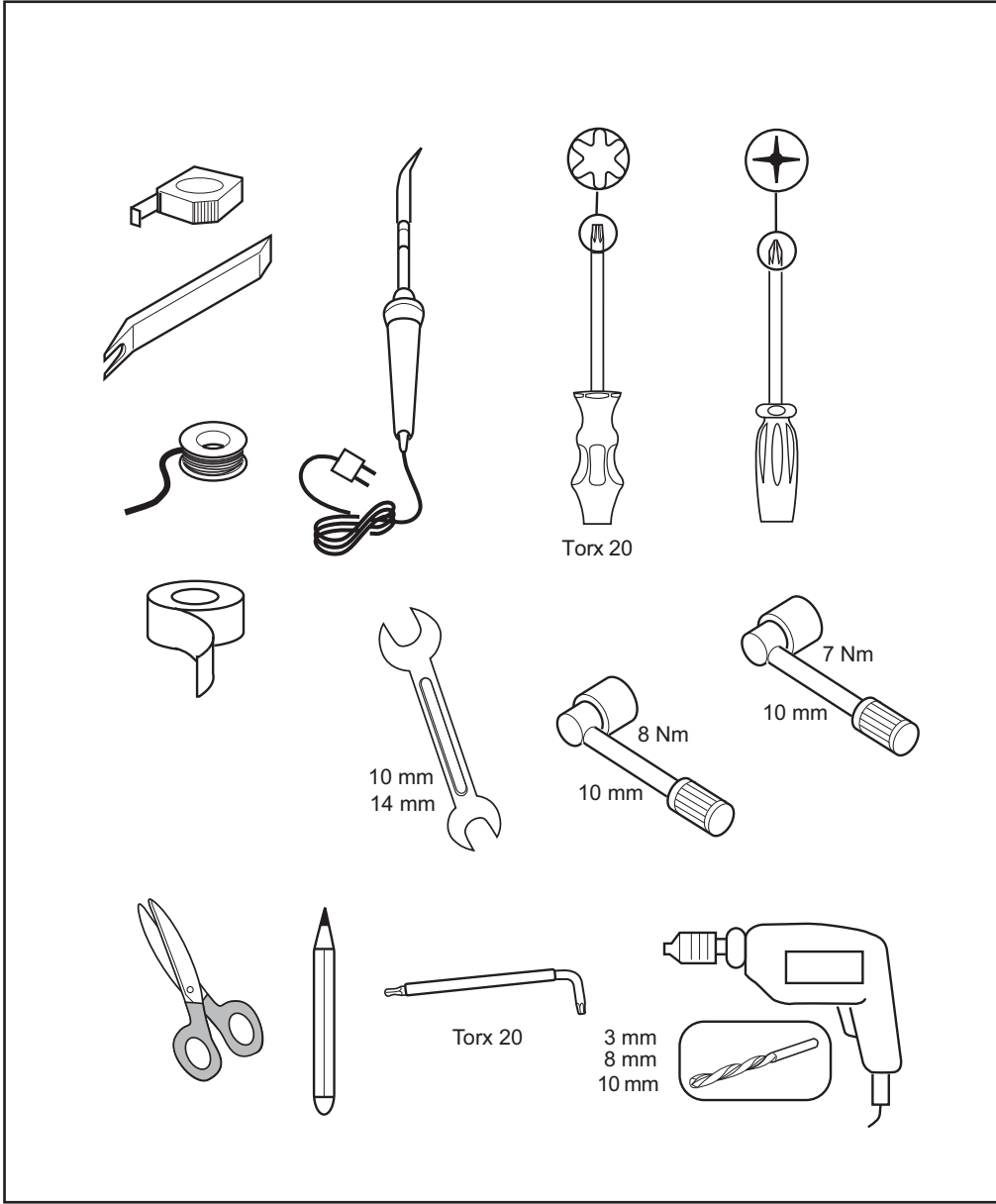

1

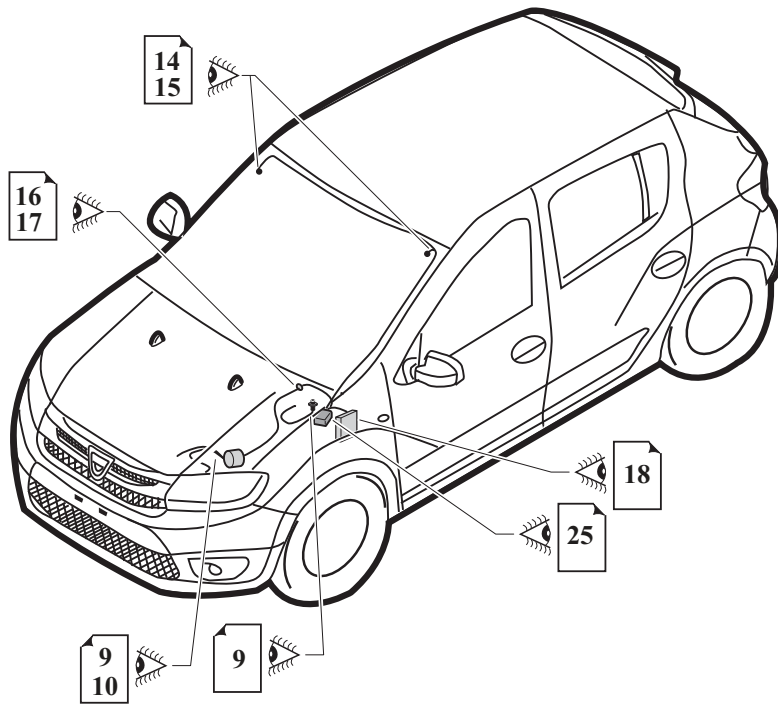

1a

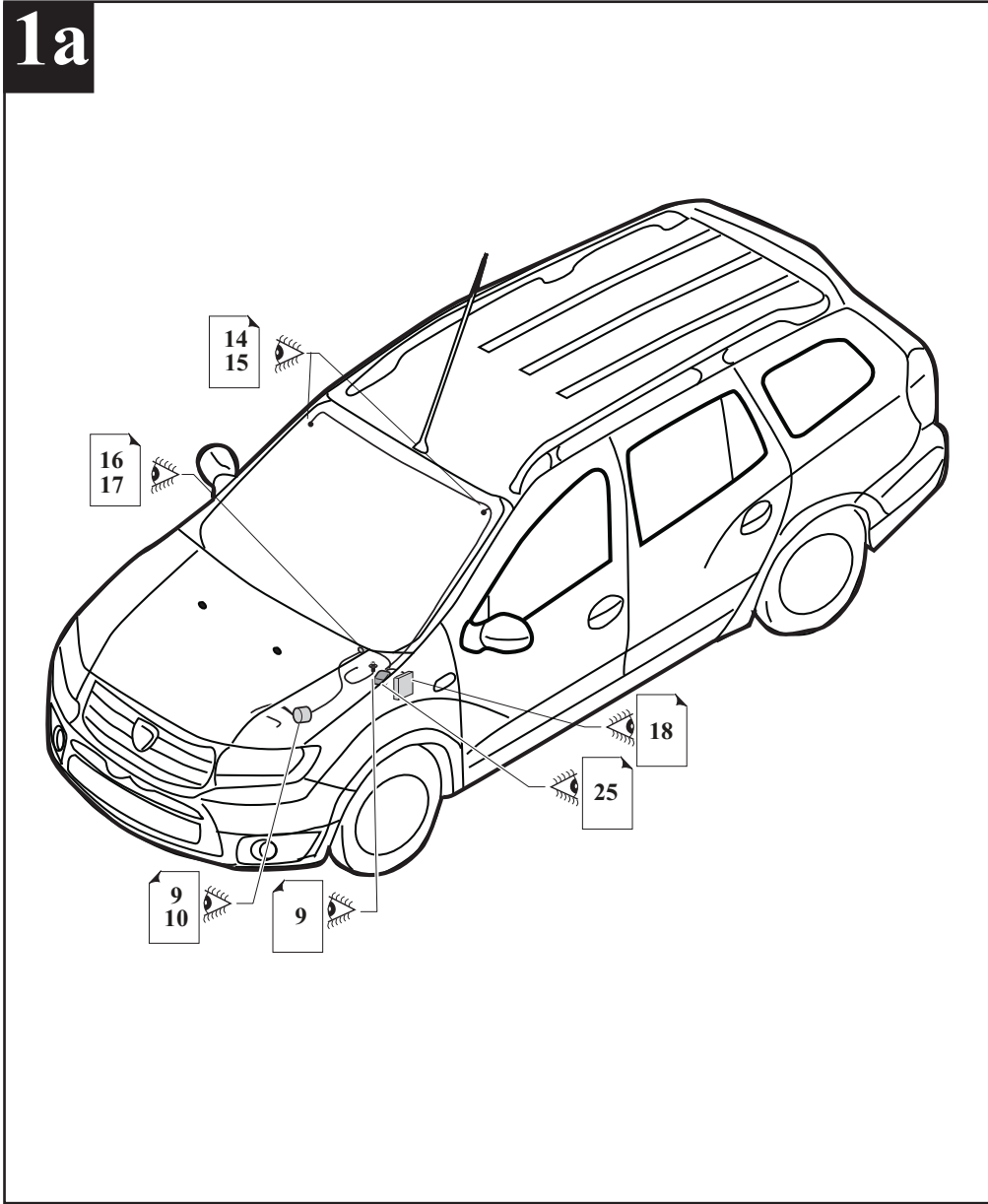

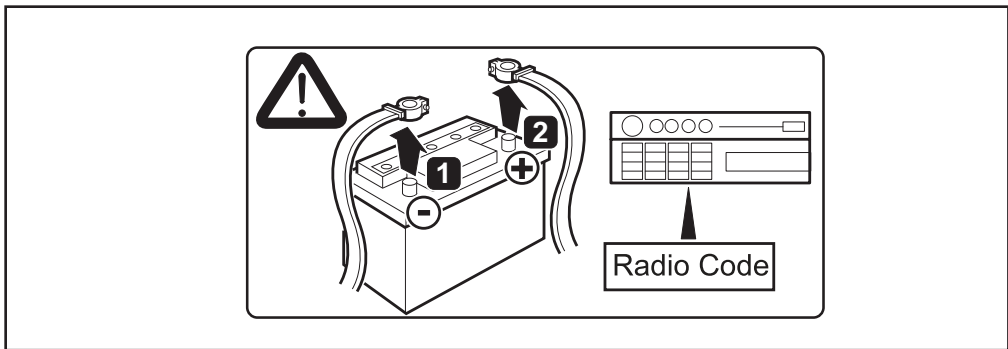
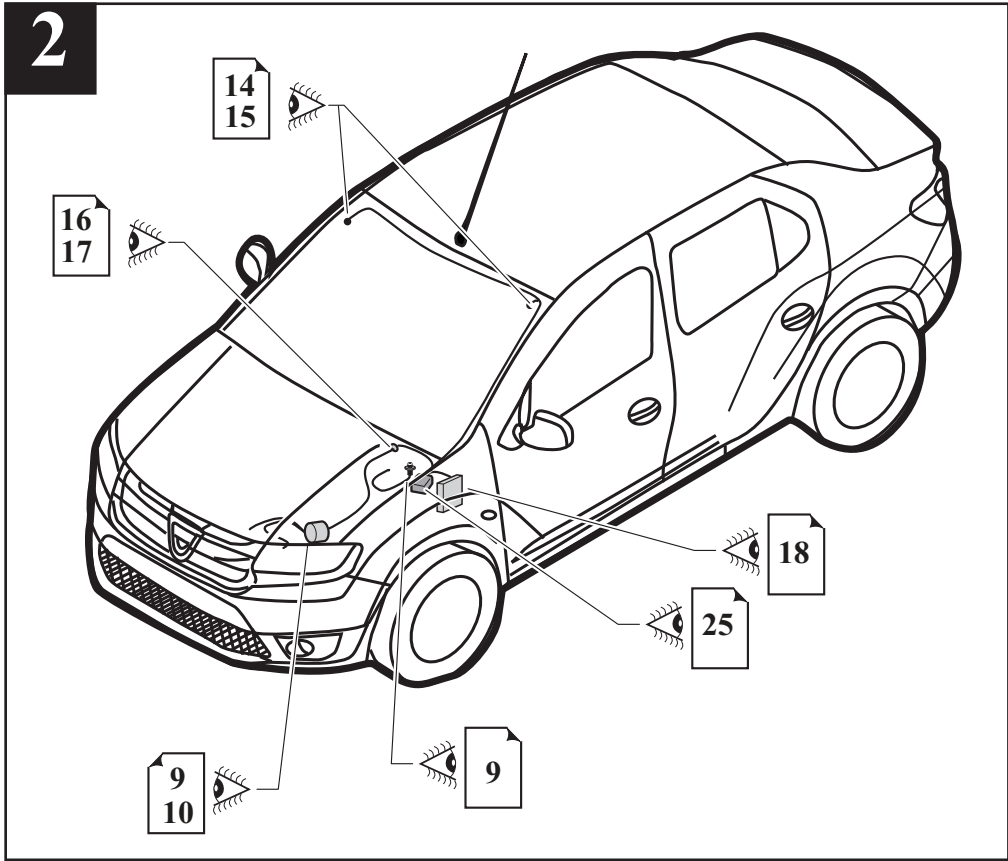

3

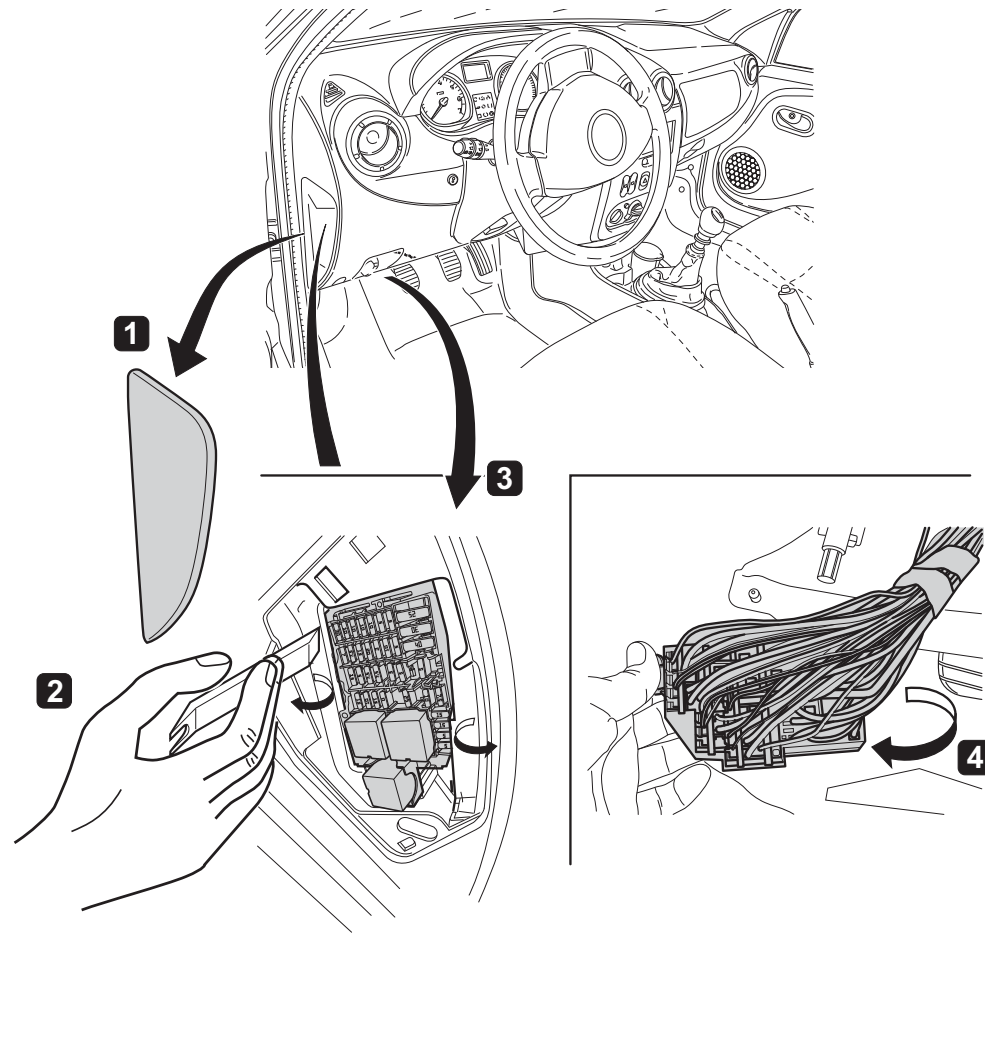

4

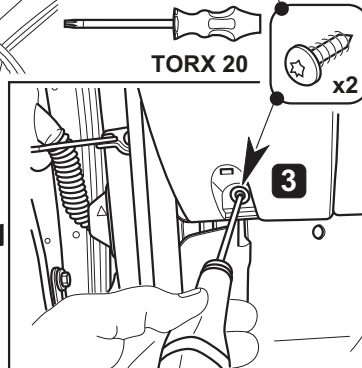
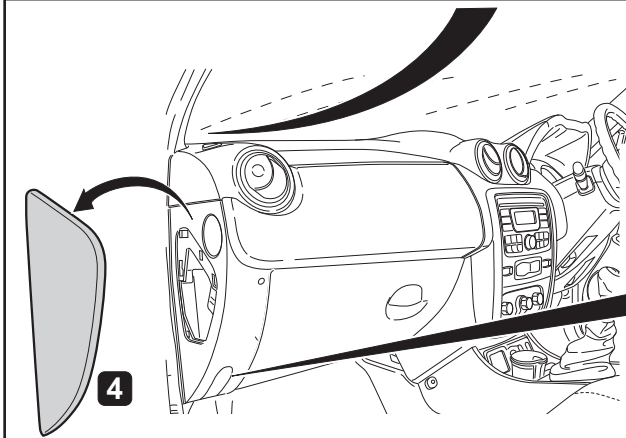
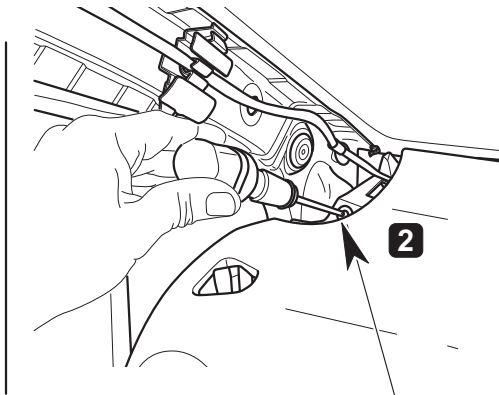
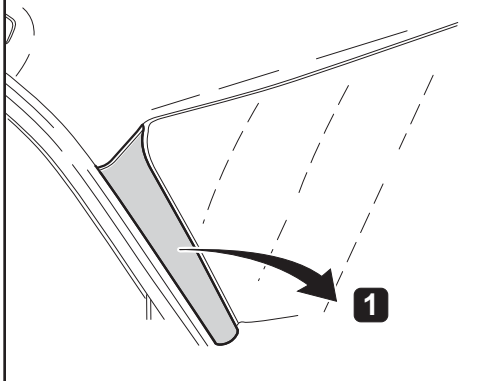
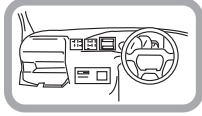

4A

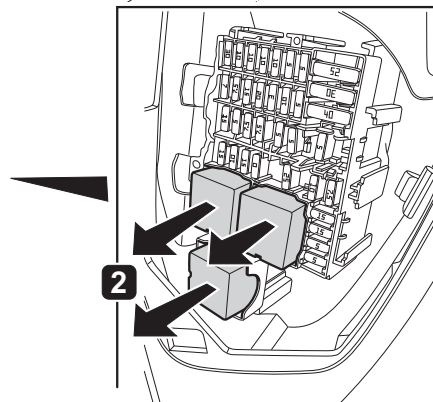
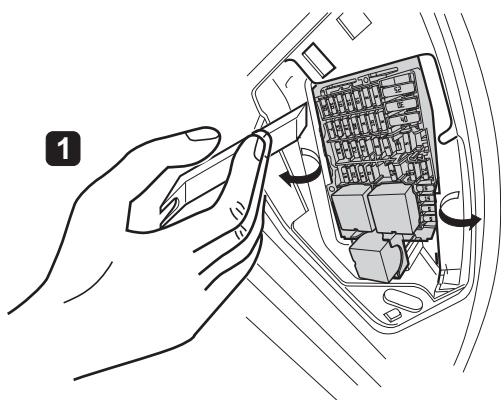
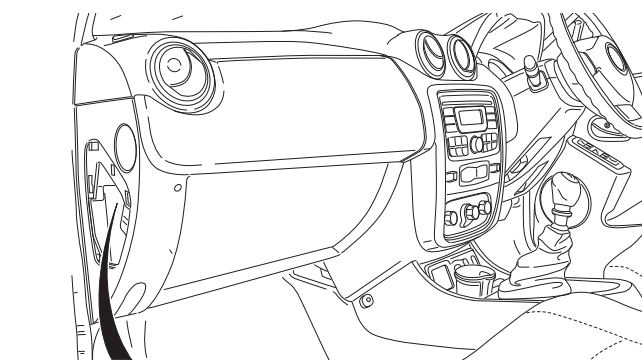
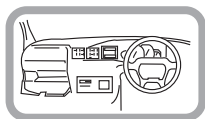

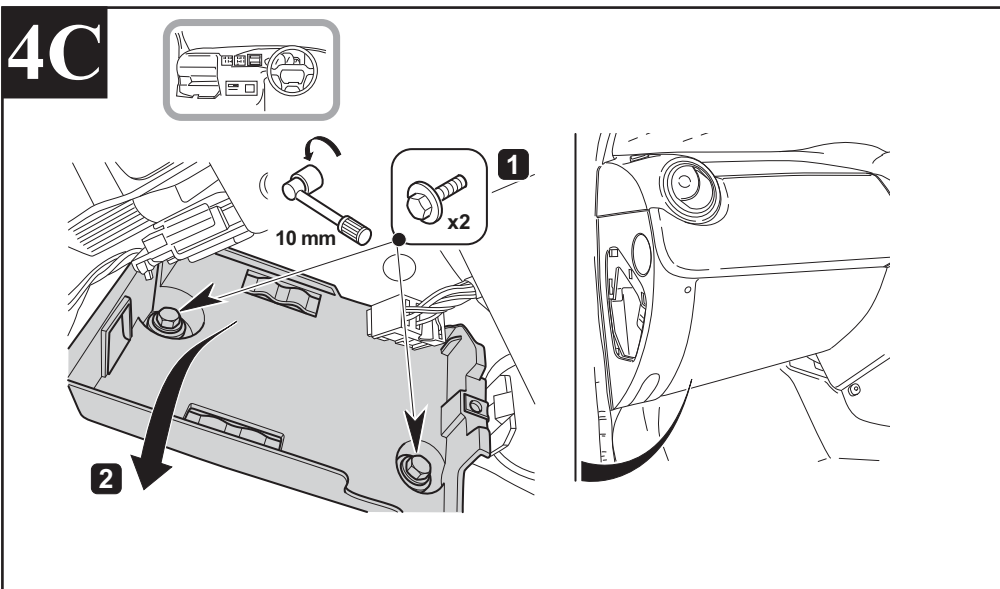
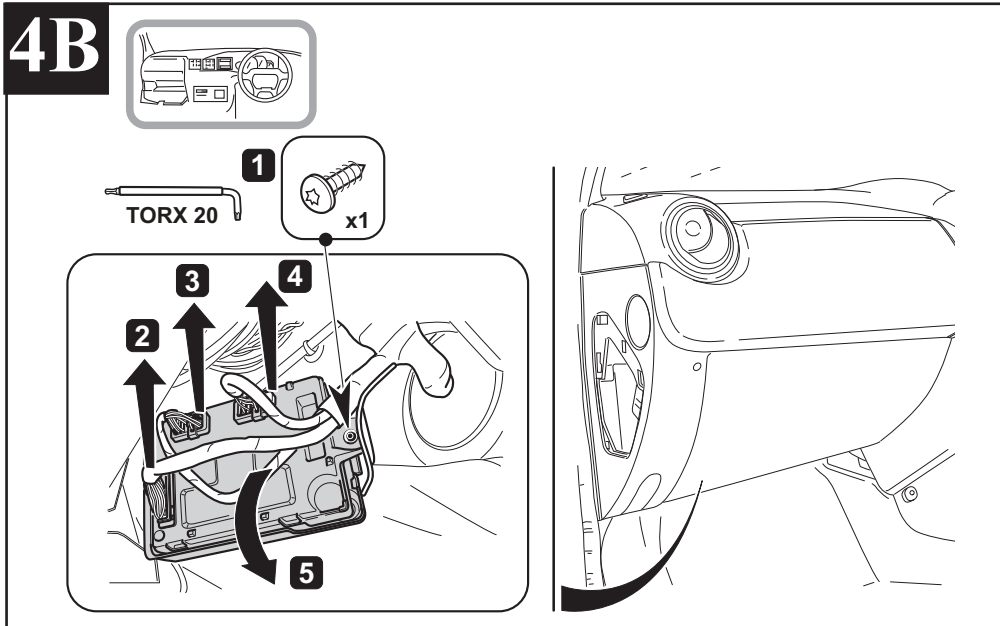

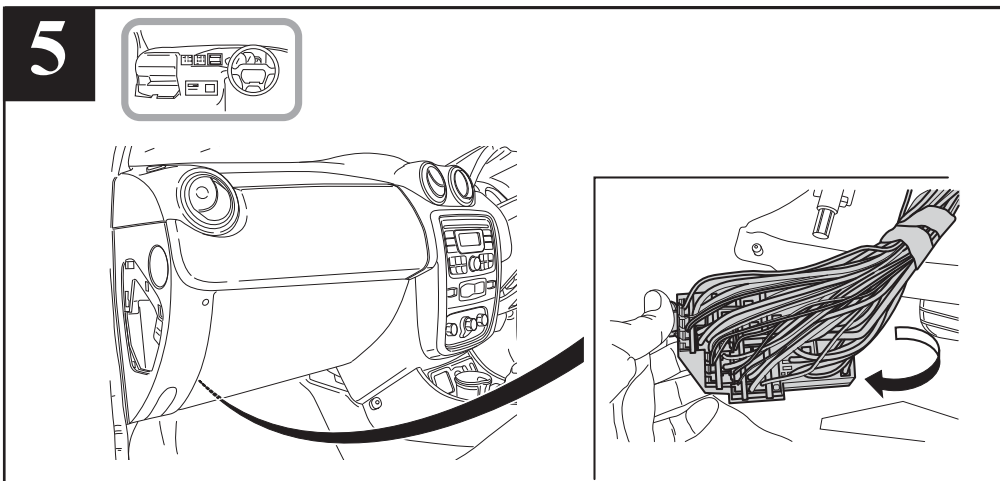
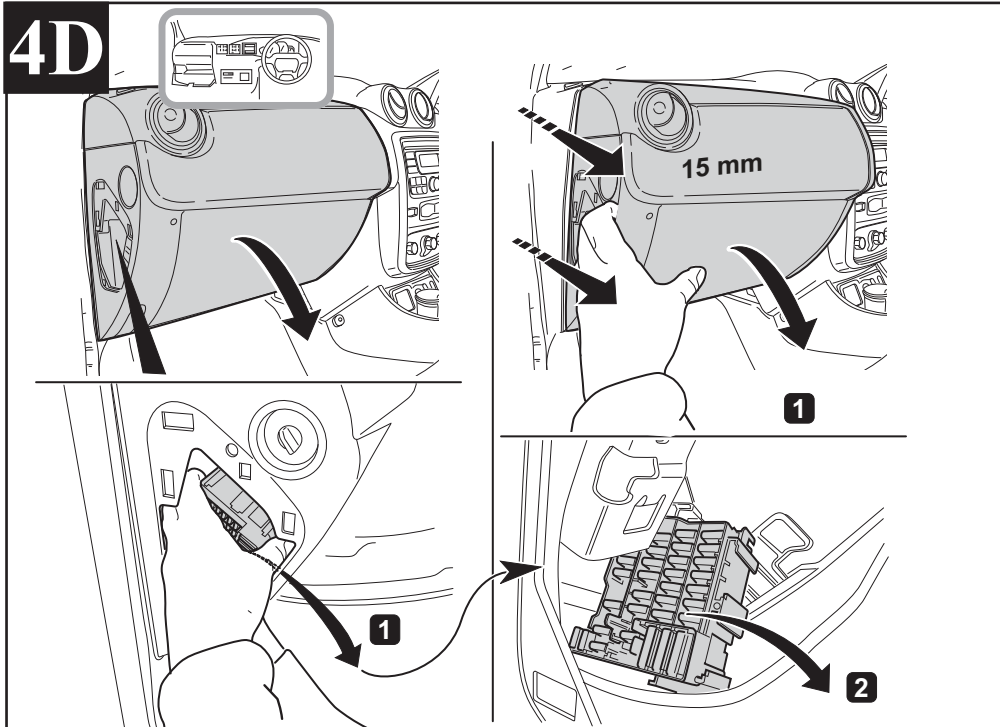

6

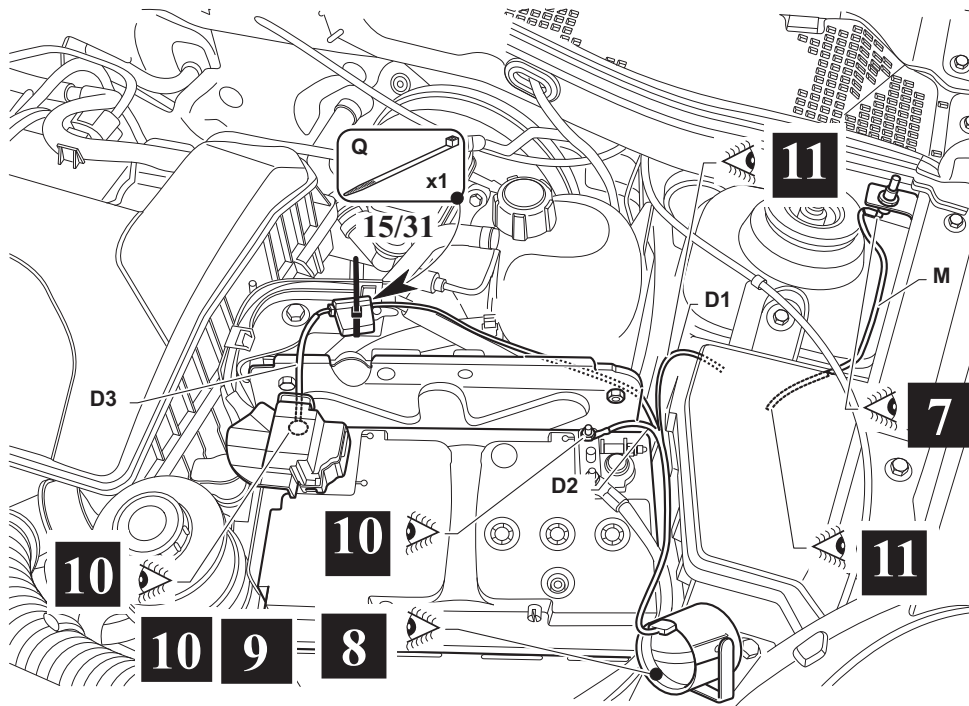

7

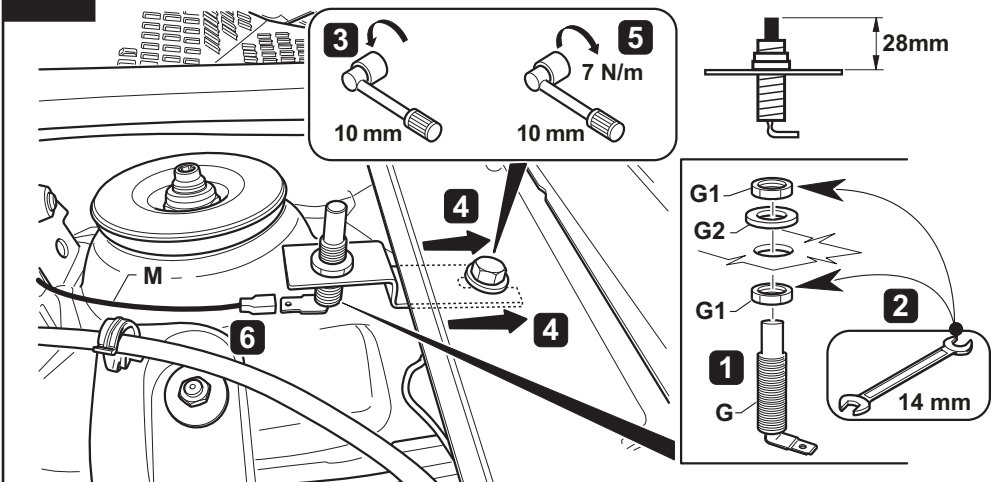

8

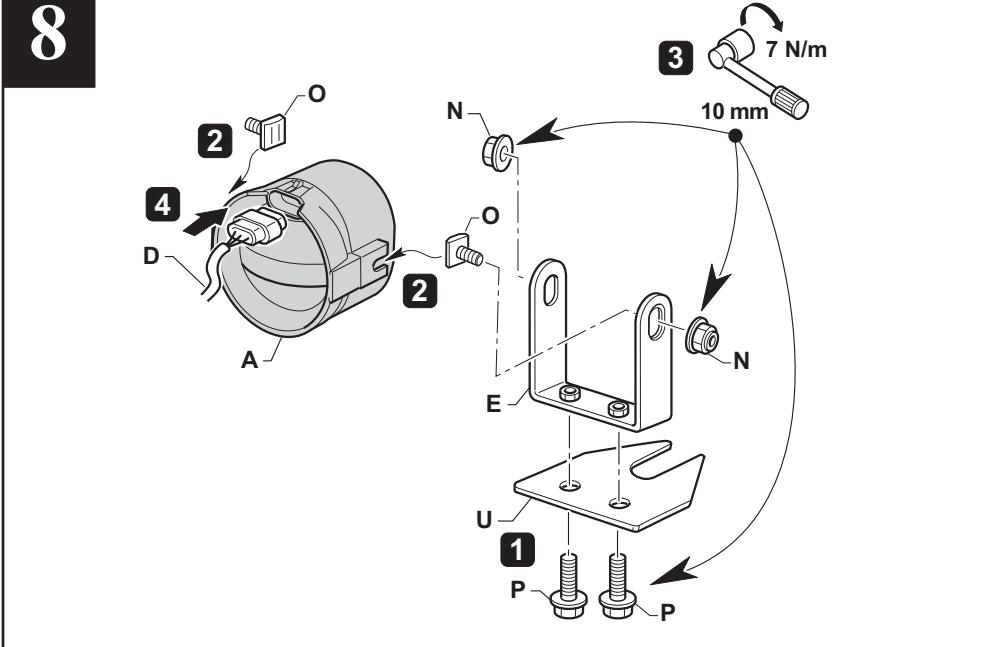

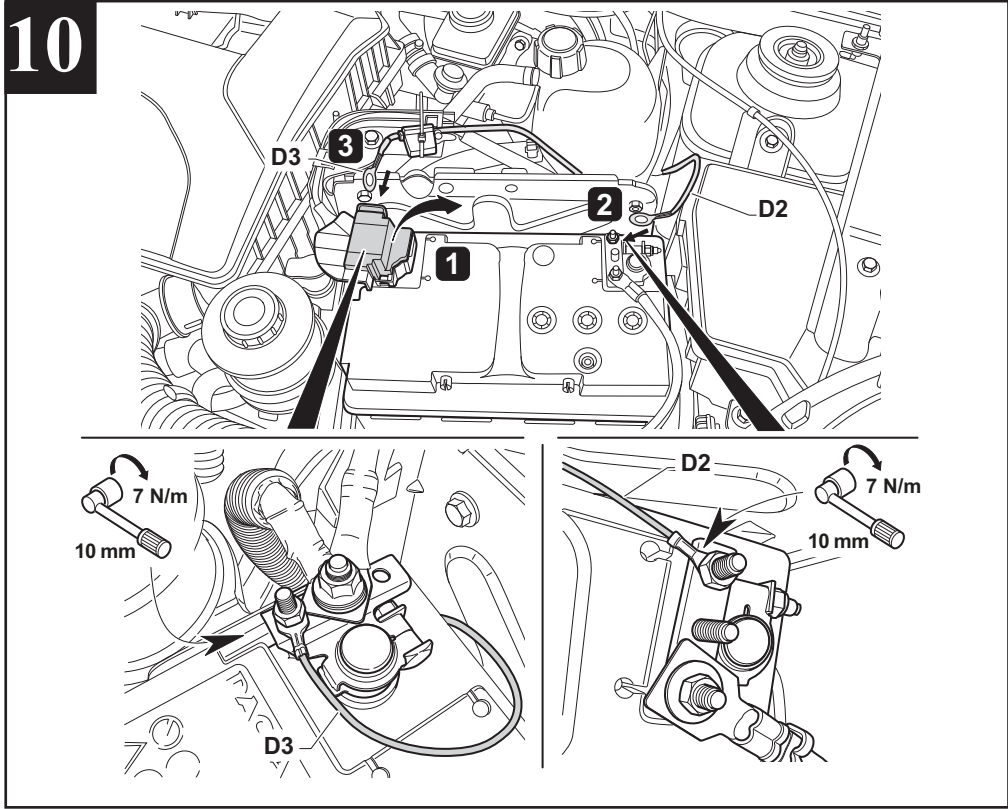
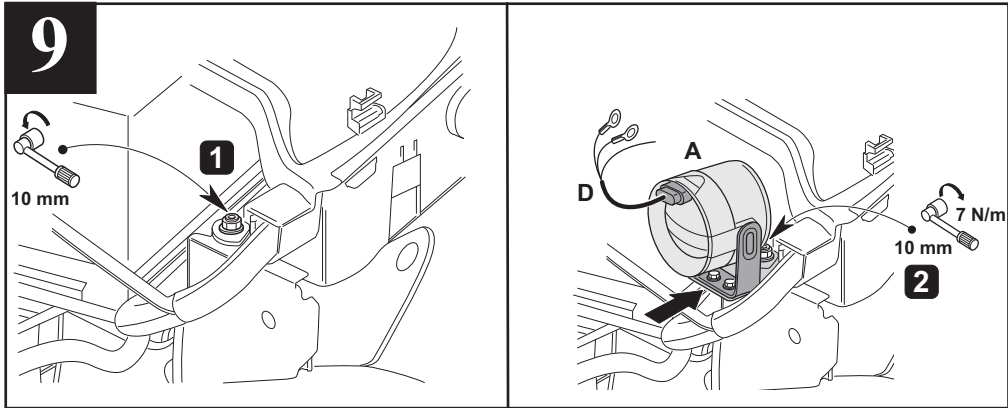

11

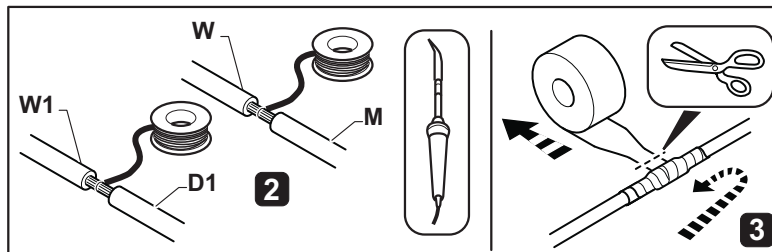
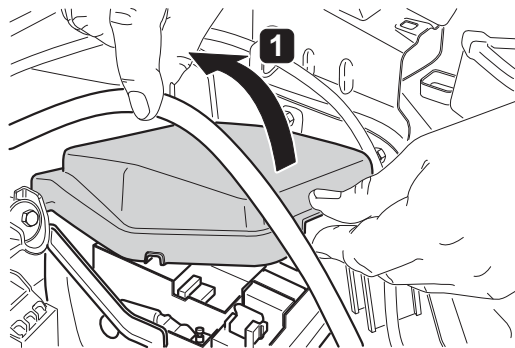

13

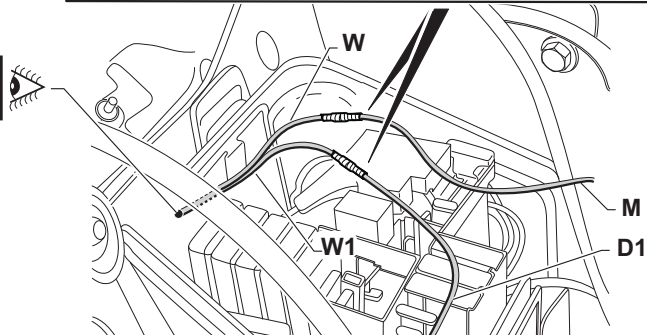

12

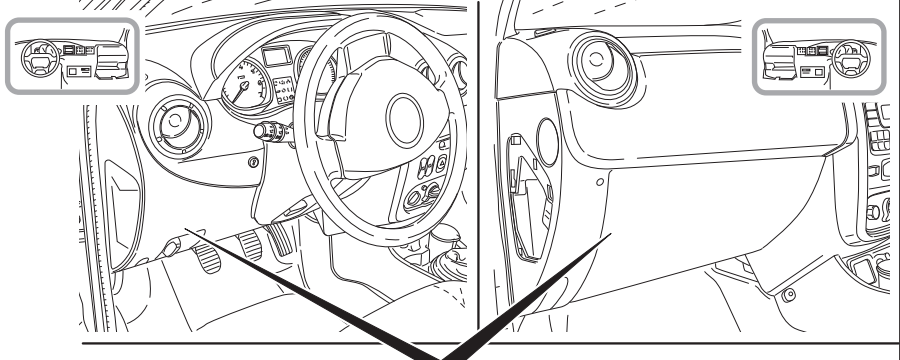

13 C17

C10 **13**

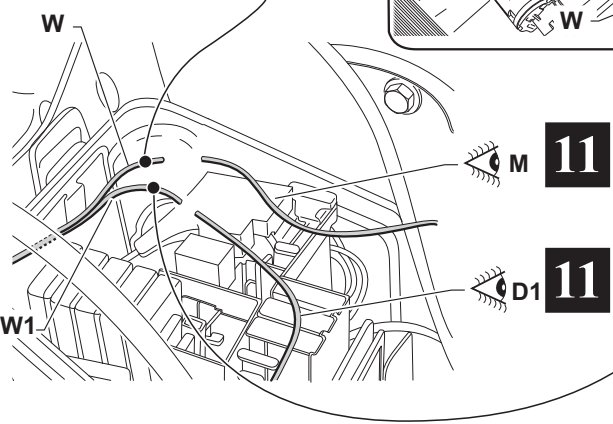
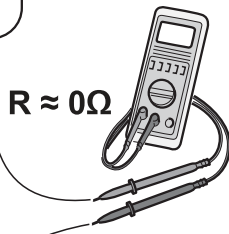
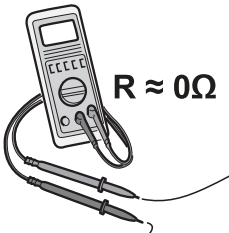

13

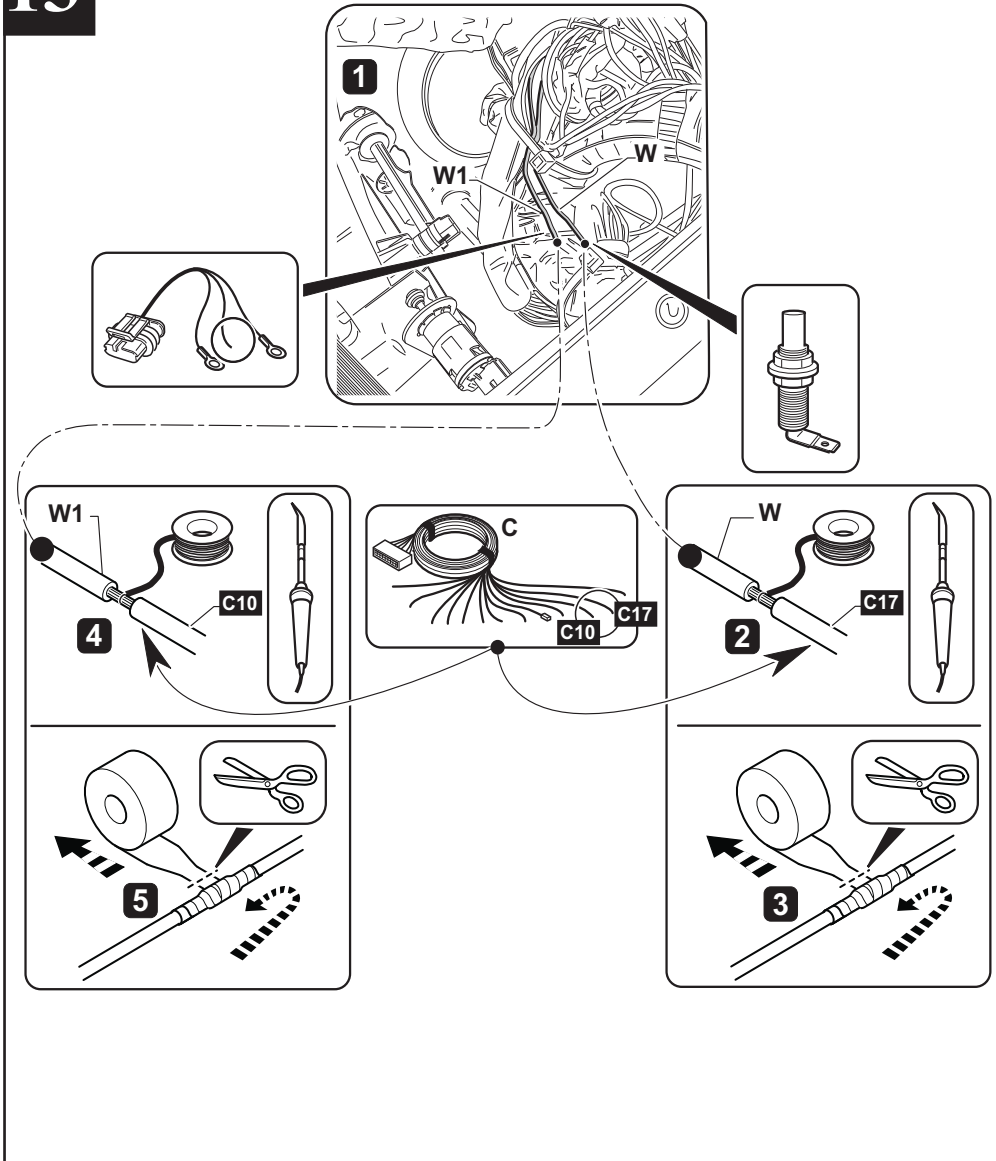

14

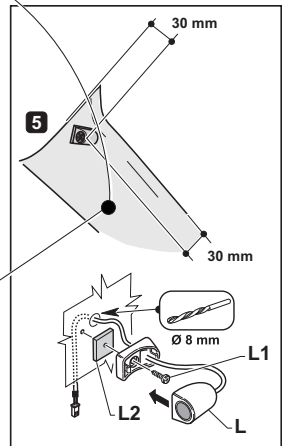
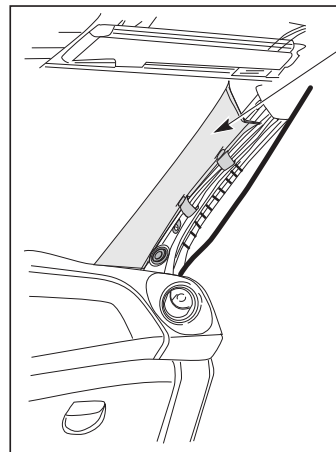
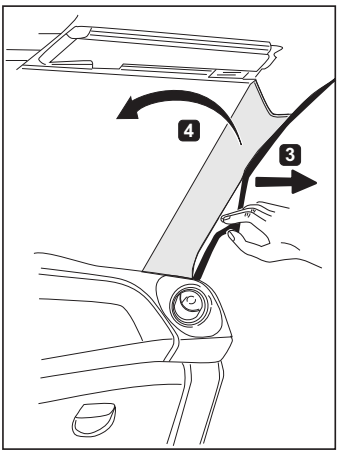
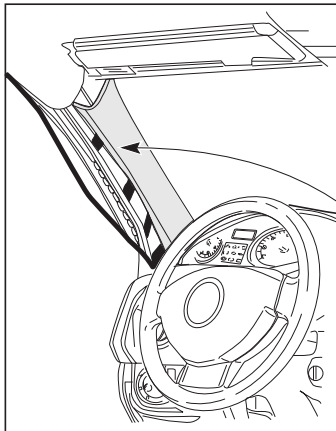
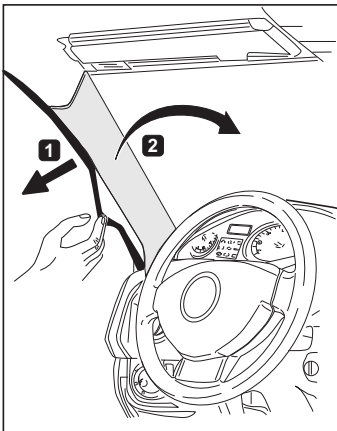
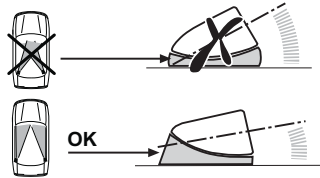
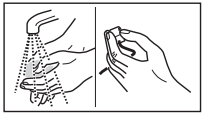

15

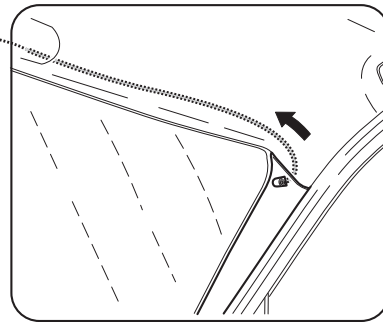
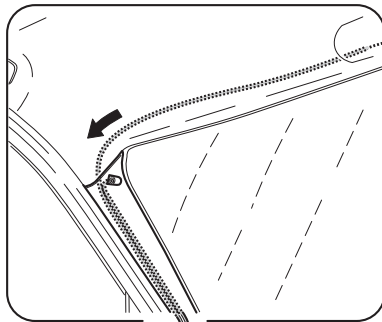
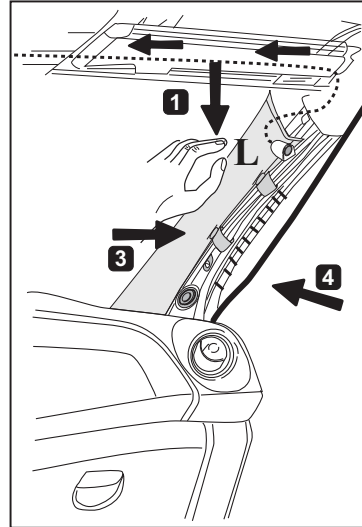
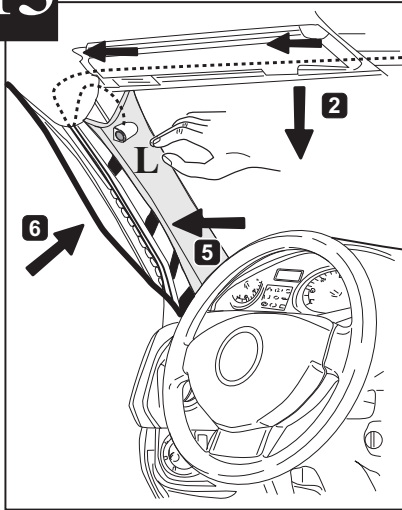

32

16

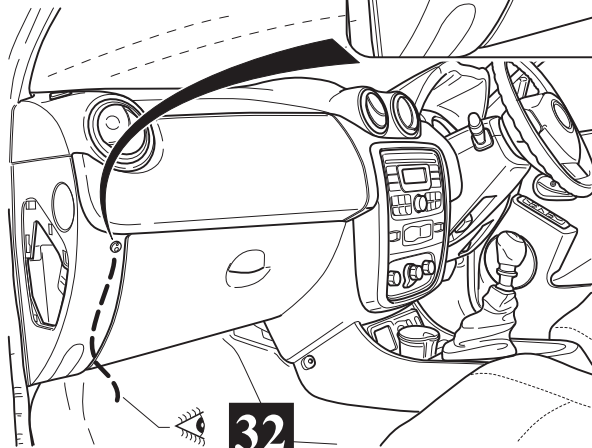
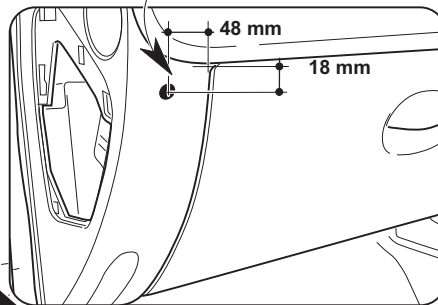
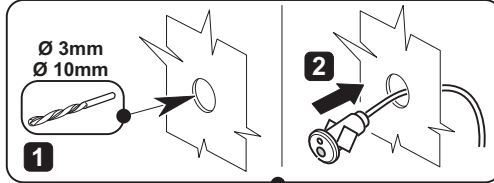
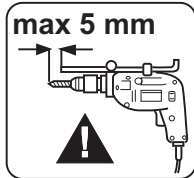
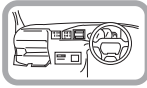

32

17

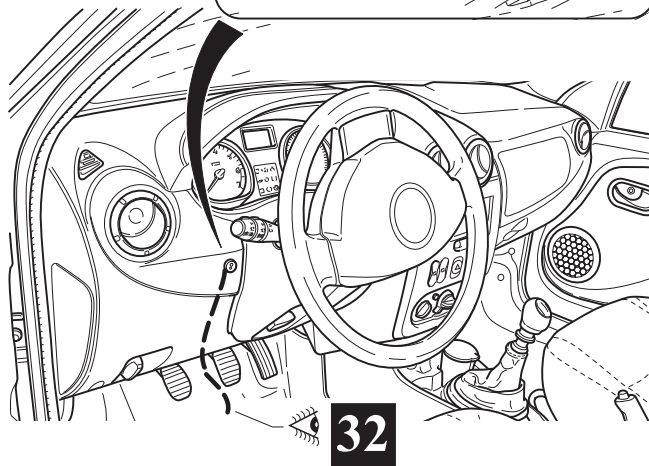
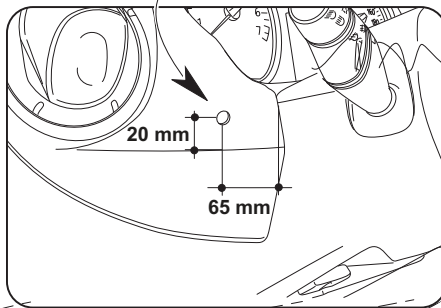
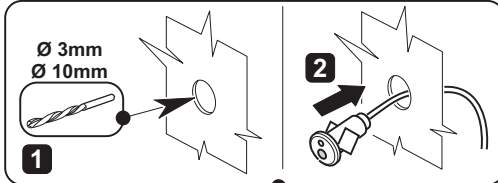
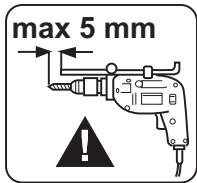
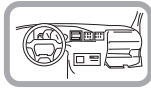

32

18

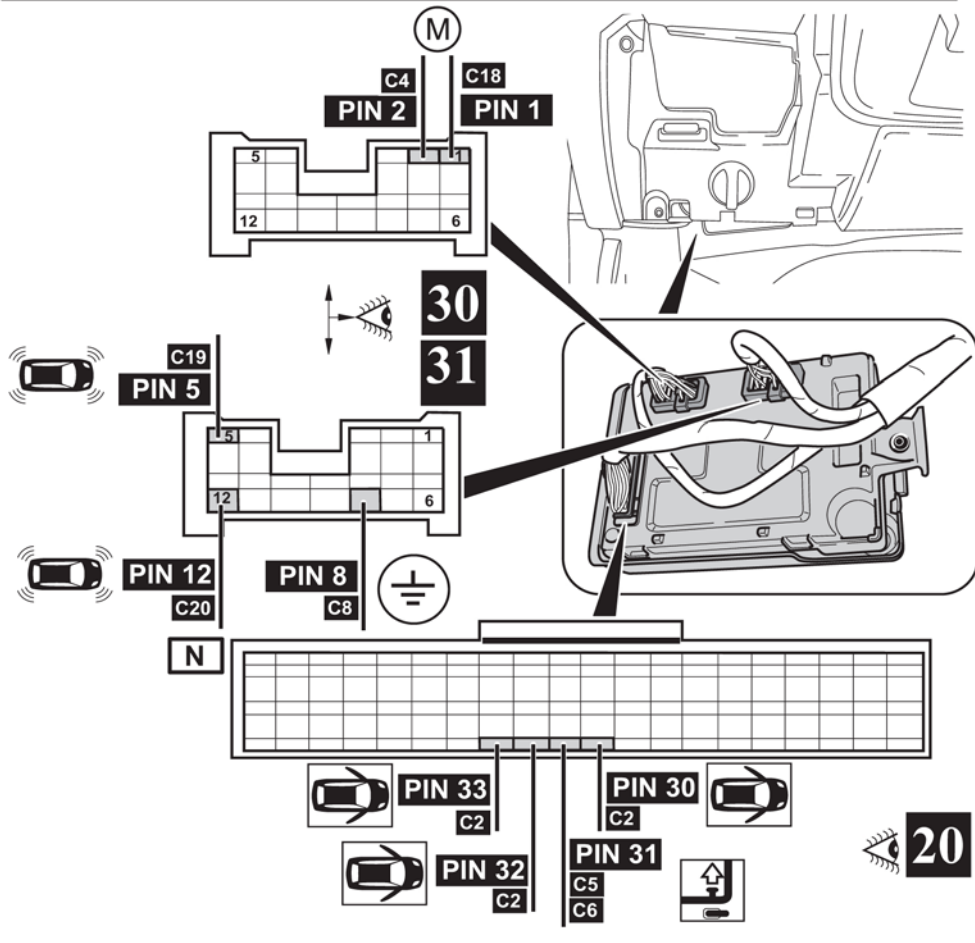
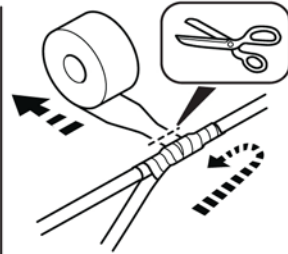
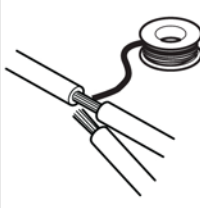

19

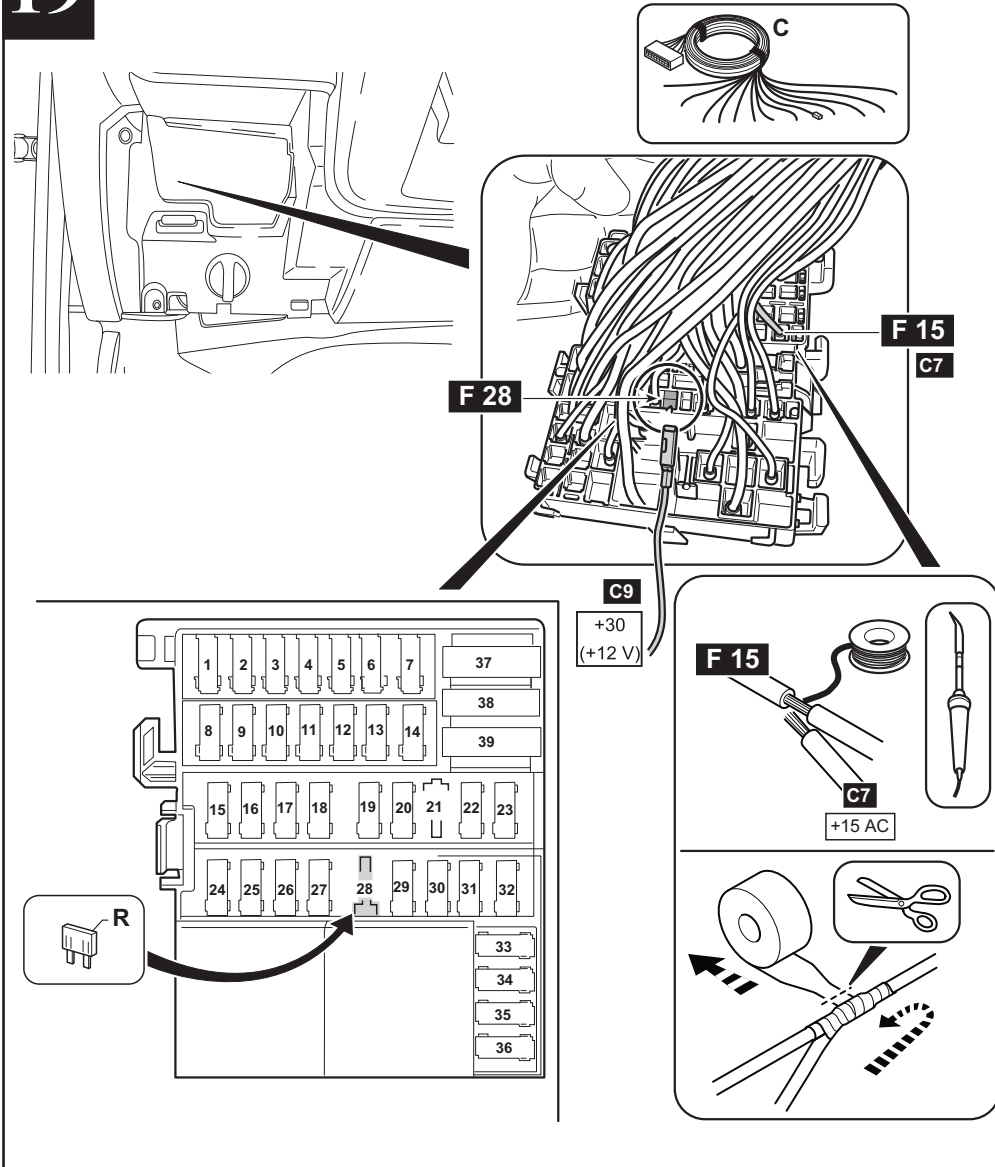

20



21



24



22



27



23

+15
AC



28



25

26

M



29

21





















			FRA	CZA	DAN	DEU	ENG	ESP	EST	FIN	GRK
		C19	jaune vert	žlutý zelený	gul grøn	gelb grün	yellow/ green	amarillo verde	kollane roherline	keltainen vihrea	κίτρινος πράσινο
		5	bleue	modrý	blå	blau	blue	azul	sinine	sininen	μπλε
		C20	jaune	žlutý	gul	gelb	yellow	amarillo	kollane	keltainen	κίτρινος
		12	saumon	losos	laks	lachs	salmon	salmon	lõhe	lohi	σολομός
			CRO	HUN	ITA	JPN	KOR	LTH	LET	NDL	NOR
		C19	žuta zelena	sárga zöld	giallo/ verde	黄色 緑	황색 녹색	geltonas žalia	dzeltens zaļš	geel groen	gul grønn
		5	plava	kék	blu	ブル	푸른	mėlinas	zils	blauw	blå
		C20	žuta	sárga	giallo	黄色	황색	geltonas	dzeltens	geel	gul
		12	łosoś	lazac	salmone	サーモ	연어	lašiša	lasis	zalm	laks
			PLK	PTG	ROM	RUS	SLK	SLV	SWE	TRK	
		C19	żółty zielony	amarelo verde	galben verde	желтый зеленый	žltý zelena	rumena zelena	gul grön	sari yesil	
		5	niebieski	azul	albastru	синий	modra	modra	blå	mavi	
		C20	żółty	amarelo	galben	желты	žltý	rumena	gul	sari	
		12	łosoś	salmão	somon	лосось	losos	losos	lax	somon	

22







			FRA	CZA	DAN	DEU	ENG	ESP	EST	FIN	GRK
☐		C8	noire	černý	sort	schwarz	black	negro	must	musta	μαύρος
		8	noire	černý	sort	schwarz	black	negro	must	musta	μαύρος
			CRO	HUN	ITA	JPN	KOR	LTH	LET	NDL	NOR
☐		C8	crn	fekete	nero	黒	검정	juodas	melns	zwart	svart
		8	crn	fekete	nero	黒	검정	juodas	melns	zwart	svart
			PLK	PTG	ROM	RUS	SLK	SLV	SWE	TRK	
☐		C8	czarny	negro	negru	черный	čierny	black	svart	siyah	
		8	czarny	negro	negru	черный	čierny	black	svart	siyah	

23















			FRA	CZA	DAN	DEU	ENG	ESP	EST	FIN	GRK
☐		C5	violett noire	fialový černý	violet sort	violett schwarz	violet black	violeta negro	lilla must	violetti musta	βιολέτα μαύρος
		31	verts	zelený	grøn	grün	green	verde	roheline	vihreä	πράσινο
		C6	l'orange noire	oranžový černý	orange sort	orange schwarz	orange black	naranja negro	oranž must	oranssi musta	πορτοκάλι μαύρος
		31	verts	zelený	grøn	grün	green	verde	roheline	vihreä	πράσινο
			CRO	HUN	ITA	JPN	KOR	LTH	LET	NDL	NOR
☐		C5	liubičie crn	ibolya fekete	viola / nero	バイオレット 黒	제비꽃 검정	violetinis juodas	violet melns	violet zwart	fiollett svart
		31	zelenilo	zöld	verde	緑	녹색	žalias	zaļš	groen	grønt
		C6	naranča crn	narancs fekete	arancione nero	オレンジ 黒	오렌지 검정	apelsinas juodas	oranžs melns	oranje zwart	orange svart
		31	zelenilo	zöld	verde	緑	녹색	žalias	zaļš	groen	grønt
			PLK	PTG	ROM	RUS	SLK	SLV	SWE	TRK	
☐		C5	fioletowy czarny	violeta negro	violet negru	фиолетовый черный	fialový ierny	violet black	violett svart	menekşe siyah	
		31	zielony	verde	verde	зеленый	zelený	zelena	grøn	yeşil	
		C6	pomarańczo czarny	laranja negro	oranj negru	оранжевый черный	oranžový ierny	oranžna black	apelsin svart	turuncu siyah	
		31	zielony	verde	verde	зеленый	zelený	zelena	grøn	yeşil	

			FRA	CZA	DAN	DEU	ENG	ESP	EST	FIN	GRK
		C2	bleu rose	modrý růžový	blå pink	blau roze	blue/ pink	azul roze	sinine roze	sininen roze	μπλε τριαντάφυ
		30	verts	zelený	grøn	grün	green	verde	roheline	vihreä	πράσινος
		C2	bleu rose	modrý růžový	blå pink	blau roze	blue/ pink	azul roze	sinine roze	sininen roze	μπλε τριαντάφυ
		32	brunes	hnědý	brun	braun	brown	marrón	pruun	ruskea	καφέ
		C2	bleu rose	modrý růžový	blå pink	blau roze	blue/ pink	azul roze	sinine roze	sininen roze	μπλε τριαντάφυ
		33	verts	zelený	grøn	grün	green	verde	roheline	vihreä	πράσινος
			CRO	HUN	ITA	JPN	KOR	LTH	LET	NDL	NOR
		C2	plava rože	kék rože	blu/ rosa	ブルー ローズ	푸른 장미	mėlynas rožė	zils sārts	blauw roze	blå rose
		30	zelenilo	zöld	verde	緑	녹색	žalias	zaļš	groen	grønt
		C2	plava rože	kék rože	blu/ rosa	ブルー ローズ	푸른 장미	mėlynas rožė	zils sārts	blauw roze	blå rose
		32	braon	barna	marrone	茶色	갈색	rudas	brūns	bruin	brun
		C2	plava rože	kék rože	blu/ rosa	ブルー ローズ	푸른 장미	mėlynas rožė	zils sārts	blauw roze	blå rose
		33	zelenilo	zöld	verde	緑	녹색	žalias	zaļš	groen	grønt
			PLK	PTG	ROM	RUS	SLK	SLV	SWE	TRK	
		C2	niebieski różowy	azul rosa	albastru roz	синий розовы	modrý ružov	blue pink	blå rosa	mavi pembe	
		30	zielony	verde	verde	зеленый	zelený	zelena	grön	yeşil	
		C2	niebieski różowy	azul rosa	albastru roz	синий розовы	modrý ružov	blue pink	blå rosa	mavi pembe	
		32	brązowy	marrom	maron	коричнев	hnědý	rjava	brun	kahverengi	
		C2	niebieski różowy	azul rosa	albastru roz	синий розовы	modrý ružov	blue pink	blå rosa	mavi pembe	
		33	zielony	verde	verde	зеленый	zelený	zelena	grön	yeşil	





25





			FRA	CZA	DAN	DEU	ENG	ESP	EST	FIN	GRK
		C10	jaunes bleue	žlutý modrý	gul blå	gelb blau	yellow/ blue	amarillo azul	kollane sinine	keltainen sininen	κίτρινος μπλε
		W1	vert	zelený	grøn	grün	green	verde	roheline	vihreä	πράσινος
			CRO	HUN	ITA	JPN	KOR	LTH	LET	NDL	NOR
		C10	žuta plava	sárga kék	giallo/ blu	黄色 ブルー	황색 푸른	geltonas mėlynas	dzeltens zils	geel blauw	gul blå
		W1	zelen	zöld	verde	緑	녹색	žalias	zaļš	groen	grønn
			PLK	PTG	ROM	RUS	SLK	SLV	SWE	TRK	
		C10	żółty niebieski	amarelo azul	galben albastru	желтый синий	zltý modrý	rumena blue	gul blå	sari mavi	
		W1	zielony	verde	verde	зелёный	zelený	zelena	grön	yeşil	





26

			FRA	CZA	DAN	DEU	ENG	ESP	EST	FIN	GRK
		D3	rouges	červený	rød	rot	red	rojo	punane	punainen	κόκκινο
		+									
		D2	noire	černý	sort	schwarz	black	negro	must	musta	μαύρος
		-									
			CRO	HUN	ITA	JPN	KOR	LTH	LET	NDL	NOR
		D3	crveno	piros	rosso	赤	붉은	raudonas	sarkans	rood	joudas
		+									
		D2	crn	fekete	nero	黒	검정	juodas	melns	zwart	svart
		-									
			PLK	PTG	ROM	RUS	SLK	SLV	SWE	TRK	
		D3	czerwony	vermelho	rosu	красный	červený	rdeča	rött	kırmızı	
		+									
		D2	czarny	negro	negru	чёрный	čierny	black	svart	siyah	
		-									



27



			(FRA)	(CZA)	(DAN)	(DEU)	(ENG)	(ESP)	(EST)	(FIN)	(GRK)	
		C17	bleue	modrý	blå	blau	blue	azul	sinine	sininen	μπλε	
		13	W	gris	šedá	grå	grau	gray	gris	hall	harmaa	γκρί



			(CRO)	(HUN)	(ITA)	(JPN)	(KOR)	(LTH)	(LET)	(NDL)	(NOR)	
		C17	plava	kék	blu	ブル	푸른	mėlinas	zils	blauw	blå	
		13	W	sive boje	szürke	grigio	グレー	회색	pilkas	pelēks	grijs	grå

			(PLK)	(PTG)	(ROM)	(RUS)	(SLK)	(SLV)	(SWE)	(TRK)	
		C17	niebieski	azul	albastru	синий	modra	modra	blå	mavi	
		13	W	szary	cinza	gri	серый	šedá	siva	grå	gri

28

			(FRA)	(CZA)	(DAN)	(DEU)	(ENG)	(ESP)	(EST)	(FIN)	(GRK)
+15 AC		C7	verts rouges	zelený červený	grøn rød	grün rot	green / red	verde rojo	roheline punane	vihreä punainen	πράσινο κόκκινο
		F15	jaune	žlutý	gul	gelb	yellow	amarillo	kollane	keltainen	κίτρινο

			(CRO)	(HUN)	(ITA)	(JPN)	(KOR)	(LTH)	(LET)	(NDL)	(NOR)
+15 AC		C7	zelenilo crveno	zöld piros	verde / rosso	緑赤	녹색 붉은	žalias raudonas	zaļš sarkans	groen rood	grønt joudas
		F15	žuta	sárga	giallo	黄色	황색	geltonas	dzeltens	geel	gul

			(PLK)	(PTG)	(ROM)	(RUS)	(SLK)	(SLV)	(SWE)	(TRK)
+15 AC		C7	zielony czerwony	verde vermelho	verde rosu	зеленый красный	zelený červený	zelena rdeča	grön rött	yeşil kırmızı
		F15	zóly	amarelo	galben	желты	žltý	rumena	gul	sari

29

			(FRA)	(CZA)	(DAN)	(DEU)	(ENG)	(ESP)	(EST)	(FIN)	(GRK)
(M)		C18	jaune noire	žlutý černý	gul sort	gelb schwarz	yellow / black	amarillo negro	kollane must	keltainen musta	κίτρινος μαύρος
		1	saumon	losos	laks	lachs	salmon	salmon	lõhe	lohi	σολομός
		C4	gris noir	šedá černý	grå sort	grau schwarz	grey / black	gris negro	hall must	harmaa musta	γκρί μαύρος
		2	blanc	bílý	hvid	weiß	white	blanco	valge	valkoinen	λευκ

			(CRO)	(HUN)	(ITA)	(JPN)	(KOR)	(LTH)	(LET)	(NDL)	(NOR)
(M)		C18	žuta crn	sárga fekete	giallo / nero	黄色 黒	황색 검정	geltonas juodas	dzeltens melns	geel zwart	gul svart
		1	łosoś	lazac	salmone	サーモ	연어	lašiša	lasis	zalm	laks
		C4	sive boje crn	szürke fekete	grigio / nero	グレー 黒	회색 검정	pilkas juodas	pelēks melns	grijs zwart	grå svart
		2	bijela	fehér	bianco	白	화이트	baltas	balts	wit	hvit

			(PLK)	(PTG)	(ROM)	(RUS)	(SLK)	(SLV)	(SWE)	(TRK)
(M)		C18	żółty czarny	amarelo negro	galben negru	желты черный	žltý čierny	rumena black	gul svart	sari siyah
		1	łosoś	salmão	somon	лосось	losos	losos	lax	somon
		C4	szary czarny	cinza negro	gri negru	серый черный	šedá čierny	siva black	grå svart	gri siyah
		2	biały	branco	alb	белый	biely	bela	vit	beyaz

30

(FRA)	(CZA)	(DAN)	(DEU)	(ENG)	(ESP)	(EST)	(FIN)	(GRK)
brunes	hnědý	brun	braun	brown	marrón	pruun	ruskea	καφέ
(CRO)	(HUN)	(ITA)	(JPN)	(KOR)	(LTH)	(LET)	(NDL)	(NOR)
braon	barna	marrone	茶色	갈색	rudas	brūns	bruin	brun
(PLK)	(PTG)	(ROM)	(RUS)	(SLK)	(SLV)	(SWE)	(TRK)	
brązowy	marrom	maron	коричнев	hnedý	gjava	brun	kahverengi	

31

FRA	CZA	DAN	DEU	ENG	ESP	EST	FIN	GRK
BLANC	BIŁY	HVID	WEISS	WHITE	BLANCO	VALGE	VALKONEN	ΛΕΥΚΟ
CRO	HUN	ITA	JPN	KOR	LTH	LET	NDL	NOR
BIJELA	FEHÉR	BIANCO	白	흰	BALTA	BALTS	WIT	HVIT
PLK	PTG	ROM	RUS	SLK	SLV	SWE	TRK	
BIAŁY	BRANCO	ALB	БЕЛЫЙ	BIELA	BELA	VIT	BEYAZ	

32

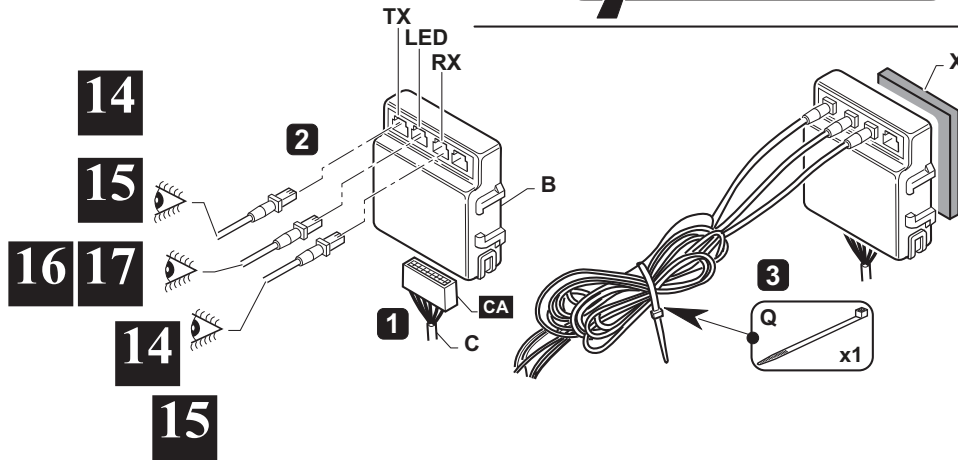
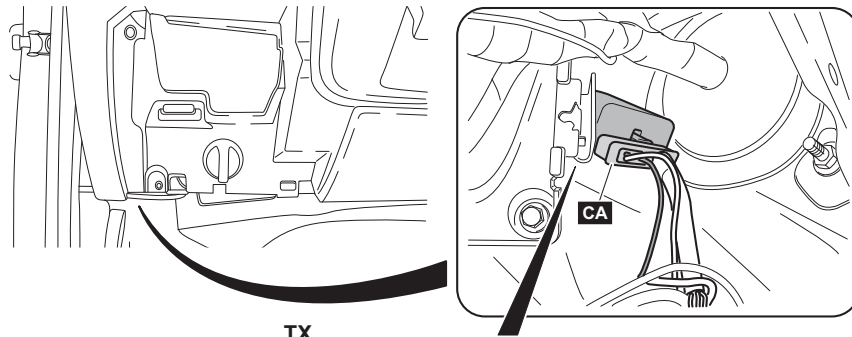

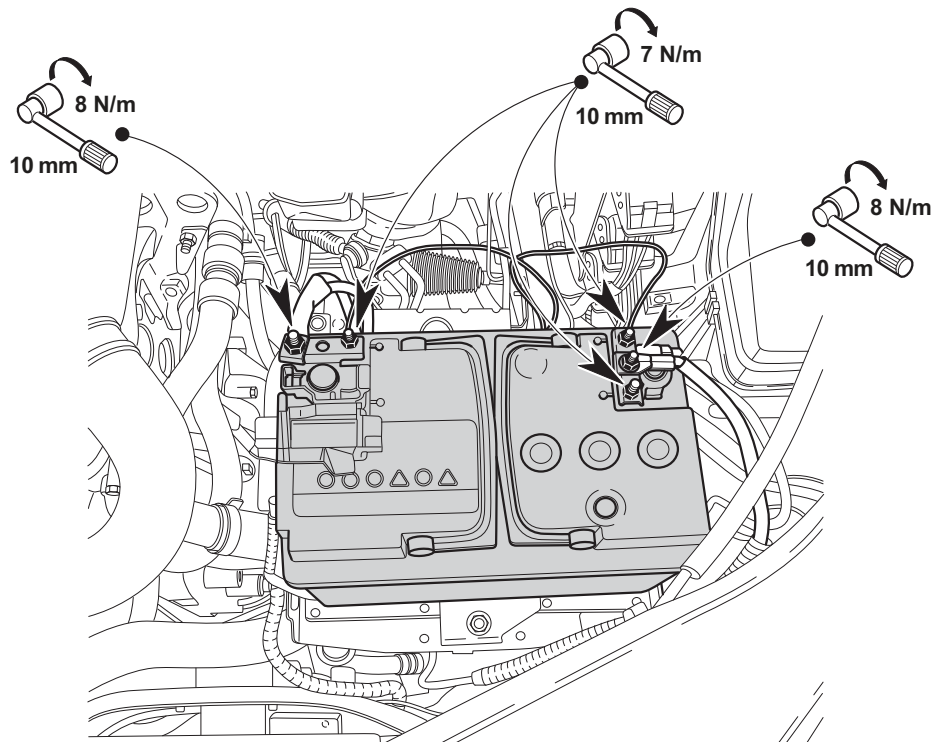
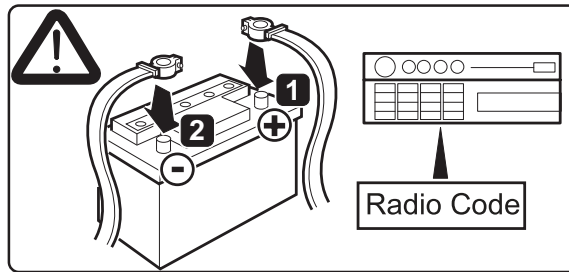

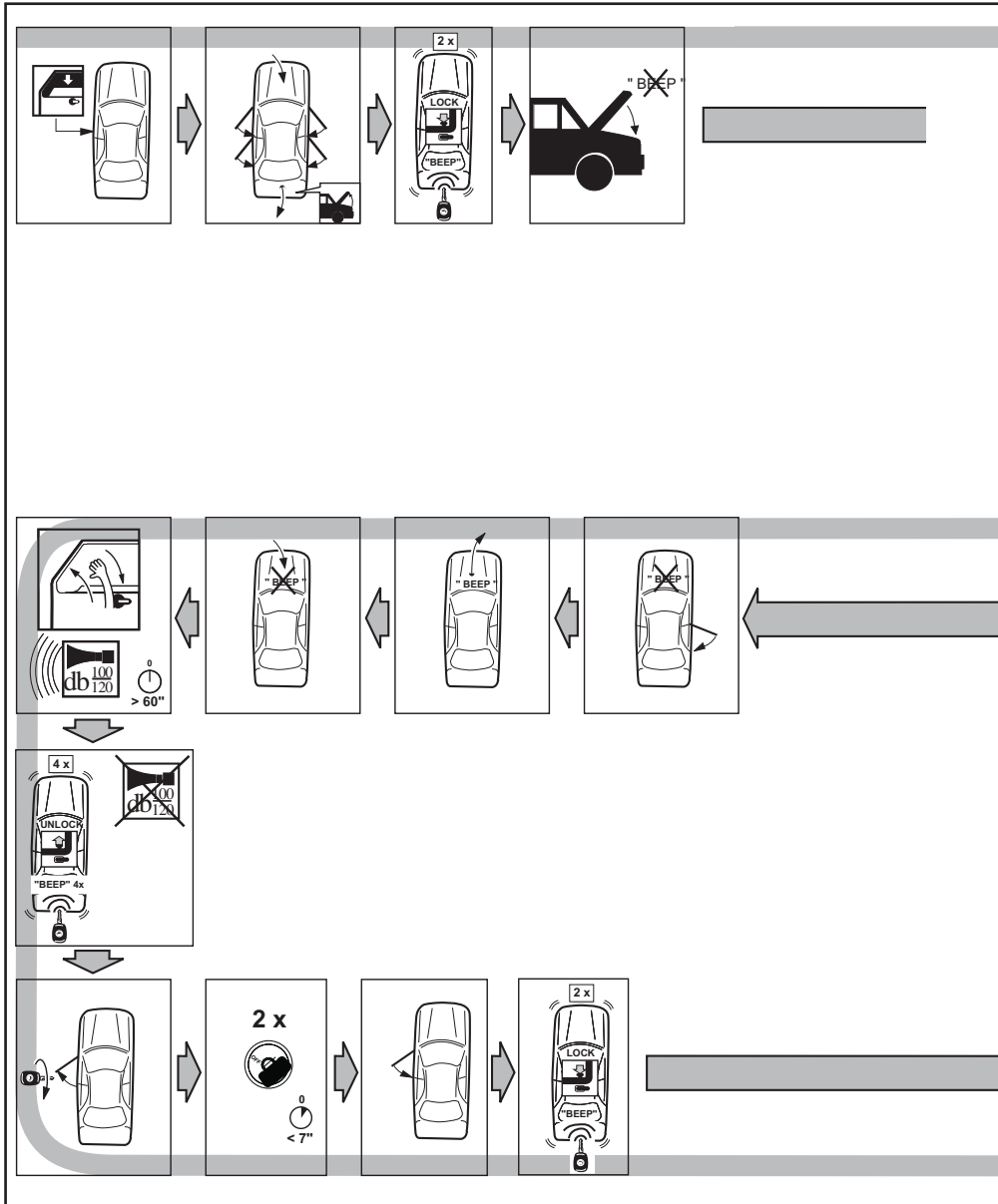

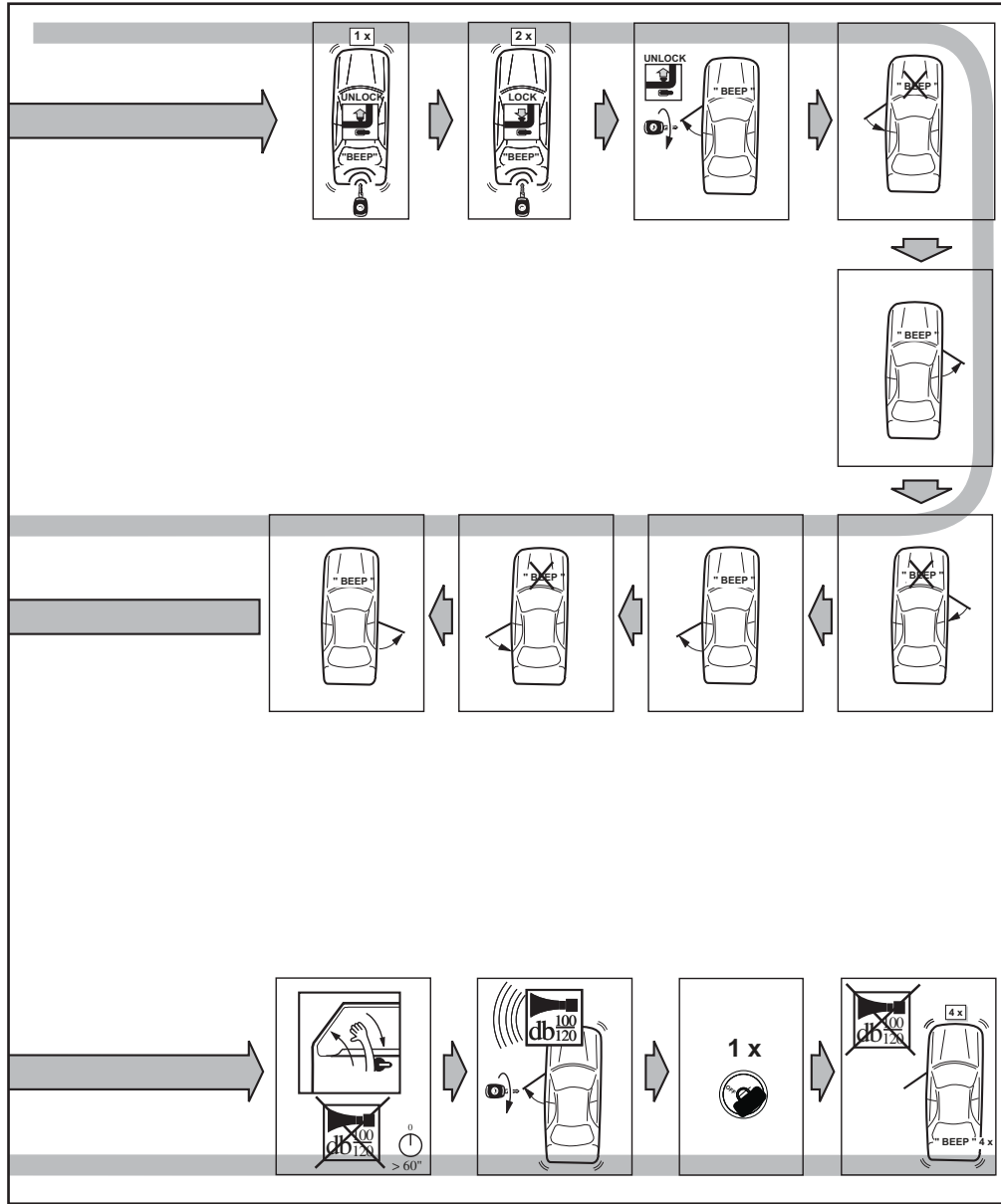

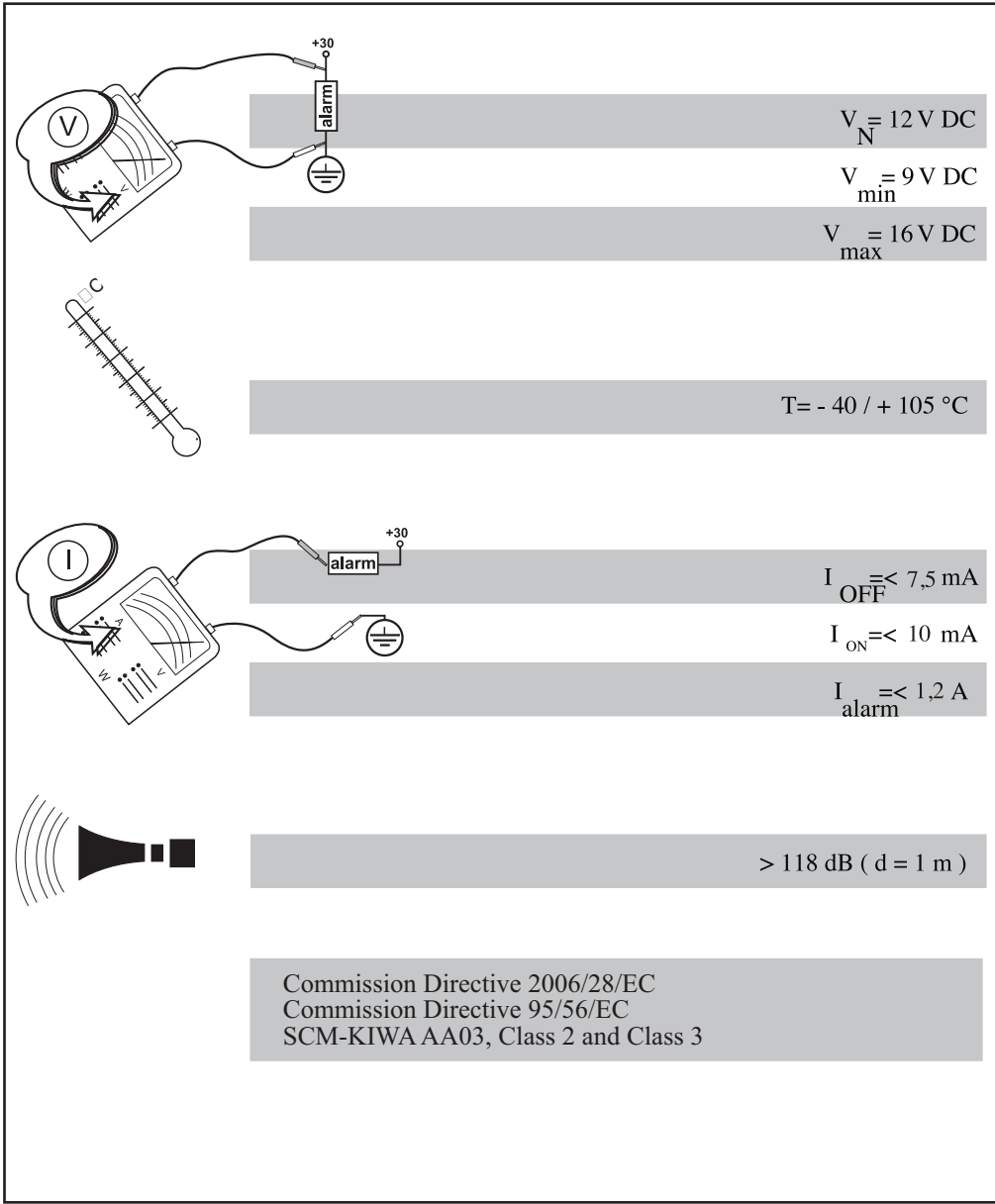

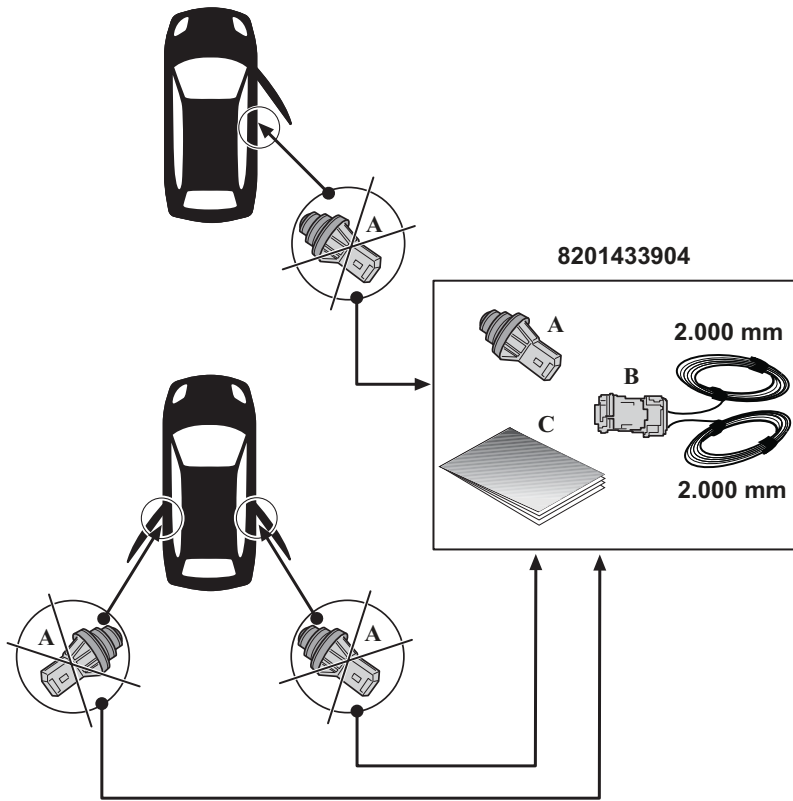

- (FRA)** Les instructions de montage et/ou d'utilisation prescrites par le constructeur, dans ce présent document, sont établies en fonction des spécifications techniques en vigueur à la date d'établissement du document. Elles sont susceptibles de modifications en cas de changements apportés par le constructeur à la fabrication des différents organes et accessoires des véhicules de sa marque. Ce produit ne doit pas être utilisé sur d'autres véhicules que ceux spécifiés en haut de la première page de la notice de montage et/ou d'utilisation. La sécurité est garantie si la conformité aux instructions de montage et/ou d'utilisation est suivie. Le non respect de cette notice dégage toute responsabilité du constructeur.
- (CZA)** Pokyny pro montáž a/nebo pro použití stanovené výrobcem jsou v tomto dokumentu sepsány podle technických specifikací platných v den jeho vydání. V případě změn provedených výrobcem při výrobě různých součástí nebo příslušenství vozidla jeho značky mohou být upraveny. Tento výrobek nesmí být používán na jiných vozidlech než na těch, která jsou specifikována v horní části první strany příručky pro montáž nebo uživatelské příručky. Bezpečnost je zaručena, pouze pokud jsou dodrženy všechny pokyny pro montáž a/nebo pro použití. Za případné nedodržení pokynů této příručky nenese výrobce žádnou zodpovědnost.
- (DAN)** Instruktionerne for montering og/eller brug som foreskrives af fabrikanten i herværende dokument, er udarbejdet ud fra de tekniske specifikationer, der var gældende på dagen, da dokumentet blev udfærdiget. Instruktionerne kan ændres, hvis fabrikanten foretager ændringer vedrørende fremstillingen af de forskellige dele og tilbehør til det vedkommende bilmærke. Dette produkt bør ikke anvendes på andre bilmodeller, end de der er angivet øverst på første side i monterings- og/eller brugsvejledningen. Der er garanti for sikkerheden, hvis instruktionerne for montering og/eller anvendelse følges. Hvis instruktionerne i denne vejledning ikke overholdes, bortfalder ethvert ansvar fra fabrikanten side.
- (DEU)** Die Montage- bzw. Bedienungsanleitungen, die im vorliegenden Dokument vom Hersteller vorgeschrieben werden, basieren auf den zum Zeitpunkt der Erstellung gültigen technischen Spezifikationen. Sie unterliegen eventuellen Änderungen im Falle von Modifikationen seitens des Herstellers bei der Fertigung verschiedener Komponenten und des Zubehörs der Fahrzeuge seiner Marke. Dieses Produkt darf bei keinem anderen als dem oben auf der ersten Seite dieser Montage- oder Bedienungsanleitung angegebenen Fahrzeug verwendet werden. Die Sicherheit ist garantiert, insofern die Montage- oder Bedienungsanleitung befolgt wird. Bei Nichtbeachtung dieser Anleitung wird vom Hersteller keine Haftung übernommen.
- (ENG)** The instructions for assembly and/or use provided by the manufacturer in this document reflect the technical specifications that were applicable at the time of writing. These instructions are subject to change if the manufacturer makes changes to the production of the subsystems and accessories used in the brand's vehicles. This product must only be used with the vehicles mentioned at the top of the first page of the assembly and/or user manual. Following the instructions for assembly and/or use will guarantee safe use of the product. The manufacturer shall not be held liable if these instructions are not followed.

- ESP** Las instrucciones de montaje y/o de utilización prescritas por el constructor en este documento se han establecido en función de las especificaciones técnicas en vigor en la fecha de elaboración del documento. Estas instrucciones pueden ser modificadas en caso de que el constructor introduzca cambios en la fabricación de las diferentes unidades y accesorios de los vehículos de su marca. Este producto solamente se puede utilizar con los vehículos especificados en la parte superior de la primera página de las instrucciones de montaje y/o de utilización. La seguridad del producto está totalmente garantizada si se siguen todas las instrucciones de montaje y/o de utilización. Sin embargo, el hecho de no respetar estas instrucciones exime al constructor de toda responsabilidad.
- EST** Selles dokumendis sisalduvad tootjapoolsed paigaldus- ja/või kasutusjuhised vastavad dokumendi koostamise hetkel kehtivatele tehnilistele eeskirjadele. Juhised võivad muutuda, kui tootja teeb muudatusi oma sõidukite erinevate komponentide ja lisavarustuse tootmises. See toode on mõeldud kasutamiseks üksnes neil sõidukitel, mis on kirjas paigaldus- ja/või kasutusjuhendi esimese lehekülje ülaservas. Turvalisus on tagatud juhul, kui paigaldus- ja/või kasutusjuhiseid järgitakse. Kui seda juhendit ei järgita, on tootja vabastatud igasugusest vastutusest.
- FIN** Tässä kirjassa esitetyt asennus-/käyttöohjeet perustuvat siihen rakenteeseen, joka oli käytössä kirjaa laadittaessa. Asennus-/käyttöohjeet saattavat muuttua komponenteissa ja varusteissa käyttöön otettujen muutosten vaikutuksesta. Tätä tuotetta saa käyttää ainoastaan niissä autoissa, jotka on listattu asennus-/käyttöohjeen ensimmäisen sivun yläreunassa. Turvallisuus on taattu, jos noudatetaan asennus-/käyttöohjeita. Jos tämän kirjan ohjeita ei noudateta, valmistaja vapautuu kaikesta vastuusta.
- GRK** Οι οδηγίες τοποθέτησης και/ή χρήσης που συνιστώνται από τον κατασκευαστή στο παρόν έντυπο έχουν καθοριστεί βάσει των τεχνικών προδιαγραφών που ίσχυαν κατά την ημερομηνία κατάρτισης του εντύπου. Ενδέχεται να υπάρχουν τροποποιήσεις σε περίπτωση που ο κατασκευαστής επιφέρει αλλαγές στην κατασκευή των διαφόρων οργάνων και εξαρτημάτων των αυτοκινήτων της μάρκας του. Απαγορεύεται η χρήση αυτού του προϊόντος σε άλλα αυτοκίνητα από εκείνα που αναφέρονται στην αρχή της πρώτης σελίδας του βιβλίου οδηγιών τοποθέτησης και/ή χρήσης. Η ασφάλεια είναι εγγυημένο εφόσον τηρούνται οι οδηγίες τοποθέτησης και/ή χρήσης. Η μη τήρηση αυτών των οδηγιών απαλλάσσει τον κατασκευαστή από οποιαδήποτε ευθύνη.
- CRO** Uputstva za postavljanje i/ili korištenje propisana od strane proizvođača, u ovom dokumentu, sastavljena su na temelju tehničkih specifikacija koje su važeće na dan izdavanja ovog dokumenta. Podložna su promjenama u slučaju da proizvođač unese promjene pri proizvodnji različitih sklopova i dodatne opreme za vozila svoje marke. Ovaj proizvod ne smije se koristiti na na drugim vozilima osim na onim navedenim na vrhu prve stranice uputstva za postavljanje i/ili upotrebu. Sigurnost je zajamčena ako se strogo slijede pravila u uputstvima za postavljanje i/ili korištenje. Proizvođač ne preuzima odgovornost u slučaju nepoštivanja ovih uputstava.
- HUN** A jelen dokumentumban szereplő, a gyártó által előírt szerelési és/vagy használati utasítások a kiadvány összeállításakor érvényben lévő műszaki jellemzők alapján lettek kialakítva. Amennyiben a gyártó a gépkocsi bizonyos szerkezeti elemeit megváltoztatja, akkor azzal együtt a szerelési/használati előírások is változhatnak. Ez a termék kizárólag a szerelési és/vagy használati útmutató első oldalának felső részén megadott gépkocsik esetén használható. A biztonságos használat csak a szerelési és/vagy használati utasítások pontos betartása esetén garantált. Az útmutató utasításainak be nem tartása esetén a gyártó semmilyen felelősséget nem vállal.

- ITA** Le istruzioni di montaggio e/o d'uso prescritte dal costruttore, nel presente documento, sono elaborate in funzione delle specificazioni tecniche in vigore alla data dell'elaborazione del documento. Sono suscettibili di modifiche qualora il costruttore apporti delle modifiche nella fabbricazione di differenti organi e accessori dei veicoli recanti il suo marchio. Questo prodotto non deve essere utilizzato su veicoli diversi da quelli specificati in alto nella prima pagina delle istruzioni di montaggio e / o d'uso. La sicurezza è garantita nel caso in cui viene osservata la conformità alle istruzioni di montaggio e/o d'uso. Il mancato rispetto di queste istruzioni declina il costruttore da ogni responsabilità.
- JPN** メーカー規定の取扱説明書や取付説明書は、各々技術仕様に応じて作成されたもので、作成日から有効となります。これらの説明書は、本メーカーによる車両の各コンポーネントおよびアクセサリーの製造変更にともない改訂されることがあります。取扱説明書や取付説明書は、各説明書の最初のページ上部に特定されている車両以外には使用できません。取扱説明書や取付説明書の記載内容を完全に遵守する場合のみ安全が保証されます。説明書の記載内容を遵守されない場合、メーカーは一切の責任を負うものではありません。
- KOR** 제작사에 의해 규정된 조립설명서 그리고/또는 사용설명서가 있는 이 서류는, 제작 날짜에 유효한 기술적인 기능을 설명하기 위해 기술되었습니다. 제작사의 다양한 장치와 부품의 수정은 사전 예고 없이 이루어질 수 있습니다. 이 제품은 조립설명서 그리고/또는 사용설명서의 첫번째 페이지의 윗부분에 언급되어 있는 차량 외에 사용해서는 안됩니다. 조립설명서 그리고/또는 사용설명서를 준수하였을 경우에 안전이 보장됩니다. 이 문서의 내용을 준수하지 않았을 때 발생하는 모든 문제는 제작사가 책임을 지지 않습니다.
- LTH** Montavimo ir / arba naudojimo instrukcijos, kurias šiame dokumente pateikė gamintojas, parašytos remiantis dokumento sudarymo metu galiojančiomis technikos specifikacijomis. Instrukcijos gali keistis, jei gamintojas pakeistų tam tikrų šios markės automobilių elementų ar prietaisų gamybą. Šį gaminį naudoti galima tik tuose automobiliuose, kurie nurodyti montavimo ir / arba naudojimo instrukcijų pirmojo puslapio viršuje. Laikantis montavimo ir / arba naudojimo instrukcijų, sauga garantuojama. Nesilaikant šiame dokumente išdėstytų nurodymų gamintojas neprisiima jokios atsakomybės.
- LET** Ražotāja sniegtās montāžas un/vai lietošanas instrukcijas šajā dokumentā atbilst tai tehniskajai specifikācijai, kas ir spēkā dokumenta sastādīšanas datumā. Tās var mainīties, ražotājam ieviešot izmaiņas savas markas automašīnu ierīču un piederumu ražošanā. Šo izstrādājumu var izmantot tikai montāžas un/vai lietošanas rokasgrāmatas pirmajā lapā norādītajās automašīnās. Drošība ir garantēta, ja tiek ievērotas montāžas un/vai lietošanas instrukcijas. Šīs rokasgrāmatas neievērošana atbrīvo ražotāju no atbildības.
- NLD** De door constructeur voorgeschreven aanwijzingen voor de montage en/of het gebruik die in dit document staan, zijn opgesteld volgens de technische richtlijnen die van kracht waren toen dit document werd samengesteld. Deze kunnen veranderen indien de constructeur fabricagewijzigingen op onderdelen of accessoires van de auto's van zijn merk heeft aangebracht. Dit product mag alleen worden gebruikt op de modellen die zijn aangegeven bovenaan de eerste bladzijde van de montage- en/of gebruiksaanwijzing. De veiligheid is alleen gegarandeerd als conform de montage- en/of gebruiksaanwijzing is gewerkt. De constructeur is niet aansprakelijk indien deze aanwijzingen niet zijn opgevolgd.

- (NOR)** Anvisningene om montering og/eller bruk som produsenten har angitt i dette dokumentet, er basert på de tekniske spesifikasjonene som var gjeldende da dokumentet ble utarbeidet. Disse kan bli gjenstand for modifikasjoner i forbindelse med produsentens endringer av fremstillingen av de ulike elementer og tilbehør for kjøretøy av dette merket. Dette produktet må ikke brukes på andre kjøretøy enn de som er angitt øverst på første side i monterings- og/eller bruksanvisningen. Sikkerheten er garantert hvis bruken er i samsvar med monterings- og/eller bruksanvisningen. Produsenten fraskriver seg alt ansvar ved manglende overhold av disse anvisningene.
- (PLK)** Instrukcje dotyczące montażu i/lub użytkowania zalecane przez producenta w niniejszej dokumentacji zostały opracowane na podstawie warunków technicznych obowiązujących w dniu redagowania tekstu. Mogą one ulec zmianom w przypadku wprowadzania przez producenta modyfikacji procesu produkcji różnych podzespołów i akcesoriów pojazdów tej marki. Wymieniony produkt powinien być używany wyłącznie w pojazdach przytoczonych w górnej części pierwszej strony instrukcji montażu i/lub instrukcji obsługi. Przestrzeganie instrukcji montażu i/lub użytkowania gwarantuje bezpieczeństwo. W przypadku nieprzestrzegania niniejszych zaleceń, producent nie ponosi żadnej odpowiedzialności.
- (PTG)** As instruções de montagem e/ou utilização prescritas pelo construtor, no presente documento, são estabelecidas em função das especificações técnicas em vigor, à data da sua redacção. Estas instruções são susceptíveis de modificação, no caso de se verificarem alterações, introduzidas pelo construtor, no fabrico dos diferentes órgãos e acessórios das viaturas da sua marca. Este produto não deve ser utilizado em veículos diferentes dos especificados na parte superior da primeira página do guia de montagem e/ou de utilização. A segurança é garantida, se forem respeitadas as instruções de montagem e/ou utilização. O desrespeito por estas instruções iliba o construtor de qualquer responsabilidade.
- (ROM)** Instrucțiunile de montare și/sau de utilizare prescrie de către constructor, în prezentul document, sunt stabilite în funcție de specificațiile tehnice în vigoare la data redactării documentului. Ele sunt susceptibile de a fi modificate în cazul schimbărilor aduse de constructor în fabricarea diferitelor organe și accesorii ale vehiculelor mărcii sale. Acest produs nu trebuie să fie utilizat pe alte vehicule decât cele specificate în partea de sus a primei pagini din manualul de montare și/sau de utilizare. Securitatea este garantată dacă conformitatea cu instrucțiunile de montare și/sau de utilizare este urmată. Nerespectarea acestui manual anulează orice responsabilitate a constructorului.
- (RUS)** Указания по установке и/или эксплуатации, описанные изготовителем в настоящем документе, соответствуют техническим условиям, действительным на момент составления руководства.
В случае внесения конструктивных изменений в изготовление деталей, узлов, агрегатов автомобиля данной модели, методы ремонта могут быть также соответственно изменены. Это изделие должно использоваться только на автомобилях, перечисленных в верхней части первой страницы руководства по установке и/или эксплуатации. Безопасность гарантируется лишь в случае неукоснительного следования указаниям руководства по установке и/или эксплуатации. Несоблюдение этих указаний снимает всякую ответственность с изготовителя.

- SLK** Inštrukcie na montáž a/alebo používanie predpísané výrobcom v tomto dokumente boli vypracované v závislosti od predpisov platných k dátumu vytvorenia tohto dokumentu. Pri zmenách zavedených výrobcom počas výroby rôznych častí a príslušenstva vozidiel danej značky sa môžu tieto inštrukcie meniť. Tento výrobok možno používať iba na vozidlá uvedené v hornej časti prvej strany návodu na montáž a/alebo používanie. Bezpečnosť možno zaručiť iba pri dodržaní inštrukcií na montáž a používanie. Nedodržanie tohto návodu zbavuje výrobcu akejkoľvek zodpovednosti.
- SLV** Navodila za montažo in/ali uporabo, ki jih določa proizvajalec v tem dokumentu, so v skladu s tehničnimi specifikacijami, ki veljajo na dan sestave tega dokumenta. Te metode se lahko spremenijo v primeru, ko proizvajalec uvede spremembe pri izdelovanju različnih naprav in dodatne opreme na vozilih svoje znamke. Ta proizvod se sme uporabiti le na vozilih, ki so določena na vrhu prve strani navodil za montažo in/ali uporabo. Varnost je zagotovljena ob upoštevanju navodil za montažo in/ali uporabo. Proizvajalec ne prevzema nobene odgovornosti v primeru neupoštevanja teh navodil.
- SWE** De monterings- och/eller användningsanvisningar som tillverkaren föreskriver i detta dokument har upprättats i enlighet med de tekniska specifikationer som gällde vid dokumentets tillkomst. De kan ändras om tillverkaren av de olika delarna och tillbehören för respektive märke gör ändringar i produktionen. Denna produkt ska inte användas på andra bilar än dem som angivits högst upp på monterings- och/eller användningsanvisningarnas första sida. Säkerheten kan endast garanteras om monterings- och användningsanvisningarna följs. Om detta meddelande inte respekteras avsåger sig tillverkaren allt ansvar.
- TRK** İşbu dokümanda, üretici tarafından öngörülen Onarım Metotları, dokümanın düzenlenme tarihinde yürürlükte olan teknik spesifikasyonlar doğrultusunda oluşturulmuştur. Bu metotlar, üretici tarafından araçların çeşitli organ gruplarının ve aksesuarlarının imalatında yapılabilecek modifikasyonlar doğrultusunda değiştirilebilir. Bu ürün, montaj ve/veya kullanım kitabının ilk sayfasının üst kısmında belirtilen araçlar dışında kullanılmamalıdır. Montaj ve/veya kullanım talimatlarına uyulduğu sürece güvenlik garanti altındadır. Bu kullanım kitabına uyulmaması halinde, üretici hiçbir şekilde sorumlu olmayacaktır.